

ISO 9001 by L.R.
PED DIR. 2014/68/UE by L.R.
ATEX DIR. 2014/34/UE by B.V.
FIRE SAFE EXECUTION by L.R.
ISO 15848 by TÜV
ANTISTATIC DEVICE by L.R.
FIRE SAFE TESTED ISO 10497 by L.R.
EAC CERTIFICATION by B.V.

TYPE
FA1
PN 10 ÷ 40
ANSI 150 ÷ 300

NORME E DIRETTIVE APPLICATE DISPONIBILI AL SEGUENTE LINK:
STANDARD AND DIRECTIVE APPLIED AVAILABLE AT FOLLOWING LINK:
http://www.adlerspa.com/pdf/NORME_ADLER.pdf

VALVOLE A SFERA "CORPO PIATTO" PASSAGGIO TOTALE

CONSTRUCTION ACCORDING TO:
BS EN 12516-2 - ANSI B16.34
ISO 14313 - EN 558

On request certified
S.I.L. 3
According to IEC 61508

On request S.S. certified
MOCA
According to
1935/2004/EU

On request C.S. certified
TPED 2010/35/UE
ADR 2019
EN 14432-2014
FROM DN 15 TO DN 80
PN 40

FULL BORE ACCORDING
TO ISO 14313

BALL VALVES "WAFER TYPE" FULL BORE
ROBINETS A BOISSEAU SPHERIQUE
"WAFER" PASSAGE INTEGRAL
FLANSCHKUGELHÄHNE IN "KOMPAKTBAUWEISE"
VOLLER DURCHGANG

WEB SITE: WWW.ADLERSPA.COM

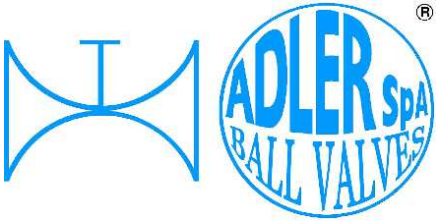

ISO 9001 by L.R.
 PED DIR. 2014/68/UE by L.R.
 ATEX DIR. 2014/34/UE by B.V.
 FIRE SAFE EXECUTION by L.R.
 ISO 15848 by TÜV
 ANTISTATIC DEVICE by L.R.
 FIRE SAFE TESTED ISO 10497 by L.R.
 EAC CERTIFICATION by B.V.

TYPE
FA1
 PN 10 ÷ 40
 ANSI 150 ÷ 300

VALVOLA A SFERA "CORPO PIATTO" PASSAGGIO TOTALE
BALL VALVES "WAFFER TYPE" FULL BORE
ROBINETS A BOISSEAU SPHERIQUE "WAFFER" PASSAGE INTEGRAL
FLANSCHKUGELHÄHNE IN "KOMPAKTBAUWEISE" VOLLER DURCHGANG

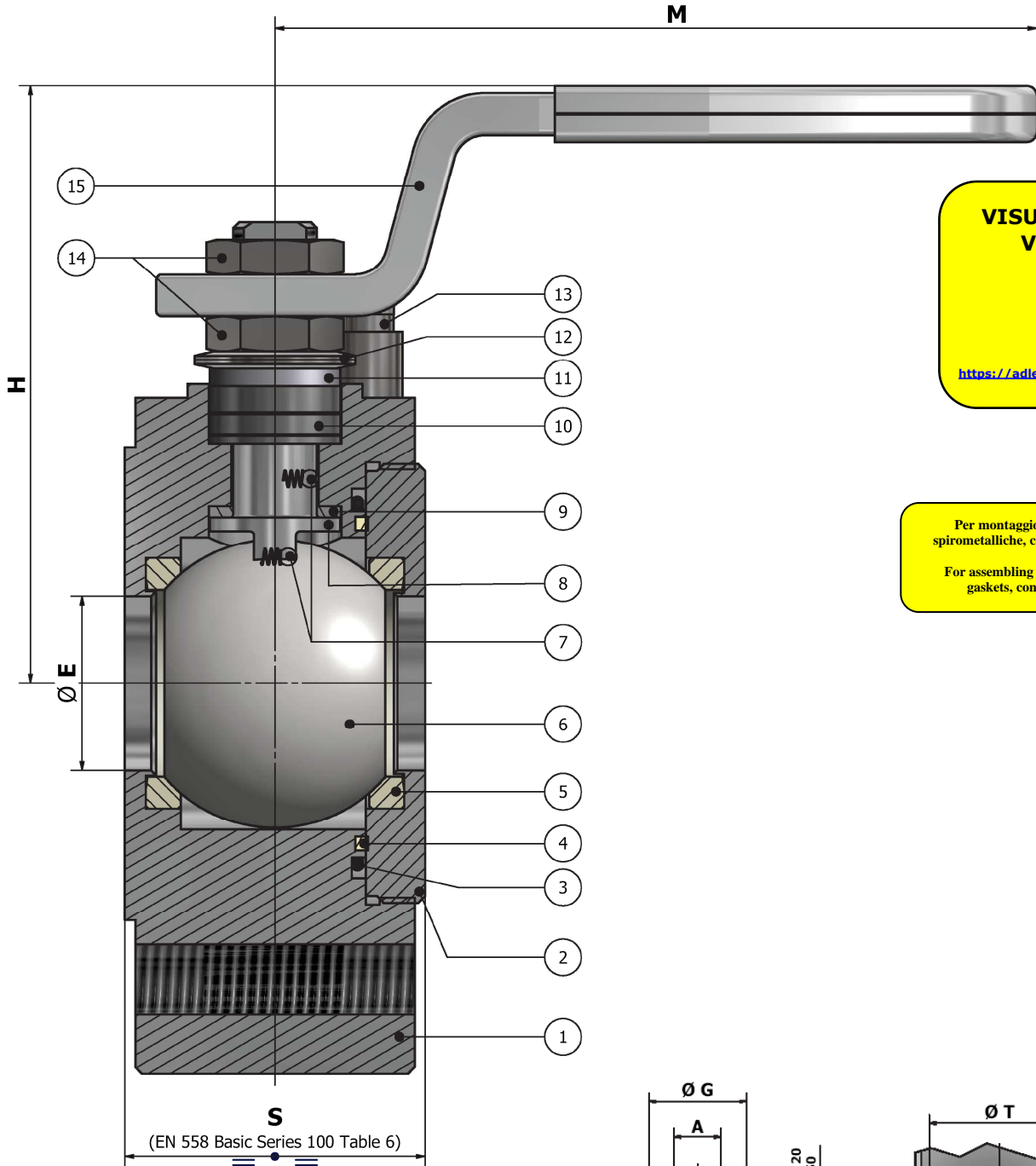

VISUALIZZA 3D
VIEW 3D

<https://adlerspa.com/prodotti/fa1>

Per montaggio con guarnizioni
 spirometalliche, contattare Adler Spa.
 For assembling with spiral-wound
 gaskets, contact Adler Spa

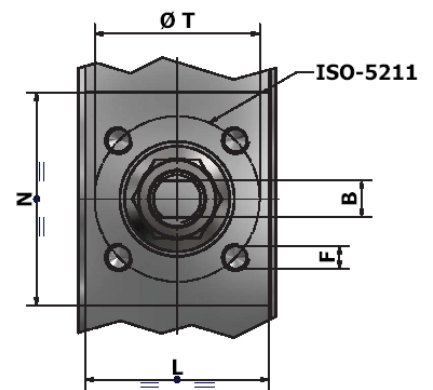
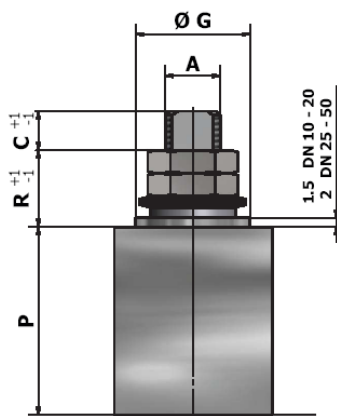

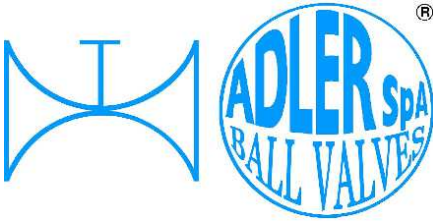

ISO 9001 by L.R.
 PED DIR. 2014/68/UE by L.R.
 ATEX DIR. 2014/34/UE by B.V.
 FIRE SAFE EXECUTION by L.R.
 ISO 15848 by TÜV
 ANTISTATIC DEVICE by L.R.
 FIRE SAFE TESTED ISO 10497 by L.R.
 EAC CERTIFICATION by B.V.

TYPE
FA1
 PN 10 ÷ 40
 ANSI 150 ÷ 300

N.	DESCRIZIONE DESCRIPTION DESCRIPTION BESCHREIBUNG	MATERIALI MATERIALS MATERIAUX WERKSTOFFE
1	CORPO BODY CORPS MITTE	ASTM A105 ASTM A479 304/304L ASTM A479 316/316L
2	GHIERA INSERT EMBOUT GEWINDEDRUCKRING	ASTM A105 ASTM A479 304/304L ASTM A479 316/316L
3*	O-RING	FKM - (VITON)
4*	ANELLO SEAL ANNEAU DICHTUNGSRING	P.T.F.E.
5*	SEDE SEAT SIEGE SITZRING	P.T.F.E. R.P.T.F.E. (OPTIONAL)
6	SFERA BALL BOULE KUGEL	ASTM A479 304/304L ASTM A351 CF8 ASTM A479 316/316L ASTM A351 CF8M
7	DISPOSITIVO ANTISTATICO ANTISTATIC DEVICE CONTACT ANTISTATIQUE ANTISTATIK VORRICHTUNG	ASTM A479 316/316L
8	STELO STEM TIGE SPINDEL	ASTM A479 304/304L ASTM A479 316/316L

N.	DESCRIZIONE DESCRIPTION DESCRIPTION BESCHREIBUNG	MATERIALI MATERIALS MATERIAUX WERKSTOFFE
9*	BUSSOLA STEM SEAL JOINT TIGE UNTERE SPINDELABDICHTUNG	P.T.F.E.
10*	PACCO A "V" CHEVRON RINGS JOINT A "V" 3 FACHE DACHMANSCHETTE	P.T.F.E. / GRAFITE P.T.F.E. / GRAPHITE P.T.F.E. / GRAPHITE P.T.F.E. / GRAPHIT
11	PREMIBUSSOLA PRESSING BUSH PRESSE RONDELLE STOPFBUCHSDRUCKRING	ASTM A479 304
12	MOLLE A TAZZA SPRING WASHERS RONDELLES BELLEVILLE TELLERFEDERN	C72/50Cr V4 ZINCATO - GALVANIZED - ZINGUE - VERZINKT X10CrNi18.8 ON REQUEST
13	VITE DI FERMO E FERMO PIN AND STOP PIN PLOINT ET PLOT D'ARRET ANSCHLAGBOLZEN	UNI 3951 A2-70
14	DADO - CONTRODADO NUT - LOCK NUT ECROU - CONTRE-ECROU MUTTER - KONTERMUTTER	UNI 3740 - 6S ZINCATO - GALVANIZED ZINGUE - VERZINKT ASTM A479 304 ON REQUEST
15	LEVA WRENCH LEVIER HANDHEBEL	AISI 1010 CHROMED FOR S.S. VALVES PAINTED FOR C.S. VALVES ASTM A479 304 ON REQUEST
16		

* RICAMBI CONSIGLIATI - RECOMMENDED SPARE PARTS - PIÈCES DE RECHANGE CONSEILLÉES - ERSATZTEIL EMPFEHLUNG

ON REQUEST P.T.F.E. AVAILABLE CERTIFIED BAM, FDA, MOCA

DIMENSIONI - DIMENSION - DIMENSIONS - ABMESSUNGEN

DN	10	15	20	25	32	40	50	65	80	100	125	150	200	250	300
A	10	10	10	12	12	16	16								
B	6	6	6	8	8	10	10								
C	7	7	7	10	10	10	10								
E	15	15	19	25	30	38	51								
F	M5	M5	M5	M5	M5	M6	M6								
ISO	F03	F03	F03	F03	F03	F05	F05								
G	25	25	25	25	25	35	35								
H	66	66	68	85	91	110	120								
L	33	33	33	40	48	58	79								
M	145	145	145	185	185	280	280								
N	69	69	78	81	105	102	102								
P	32,5	32,5	35	41	46,5	55	65								
R	7,5	7,5	7,5	16,5	16,5	19,5	19,5								
P	32,5	32,5	36,5	42,5	46,5	55	74,5								
R	8	8	6	17	16,5	20	10								
S	35	35	37	43	51	64	84								
T	36	36	36	36	36	50	50								
~Kg	1,6	1,6	1,9	2,8	4,8	7,2	11,5								

- DATI E CARATTERISTICHE SOGGETTI A VARIAZIONI SENZA PREAVVISO
- SPECIFICATIONS SUBJECT TO MODIFICATIONS WITHOUT PRIOR NOTICE
- TOUS DROITS DE MODIFICATION RESERVES
- KONSTRUKTIONÄNDERUNGEN VORBEHALTEN

PN 10 ÷ 40 - ANSI 150

ANSI 300



ADLER SpA - BALL VALVES
 20010 S. STEFANO TICINO (MI) ITALY V.le BORLETTI, 14 Tel. +39/02974842.11 FAX +39/0297271698
 E-mail: adler@adlerspa.com <http://www.adlerspa.com>

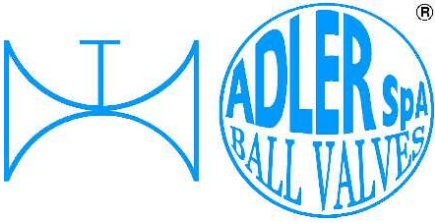

ISO 9001 by L.R.
 PED DIR. 2014/68/UE by L.R.
 ATEX DIR. 2014/34/UE by B.V.
 FIRE SAFE EXECUTION by L.R.
 ISO 15848 by TÜV
 ANTISTATIC DEVICE by L.R.
 FIRE SAFE TESTED ISO 10497 by L.R.
 EAC CERTIFICATION by B.V.

TYPE
FA1
 PN 10 ÷ 40
 ANSI 150 ÷ 300

• ESECUZIONI • EXECUTIONS • EXECUTIONS • AUSFÜHRUNGEN



EXECUTION 4- 12

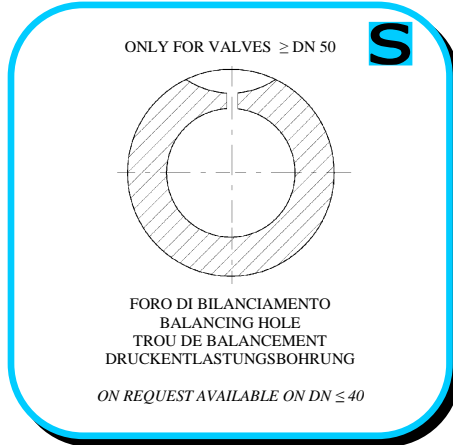

EXECUTION 6 - 16

S STANDARD

O OPTIONAL

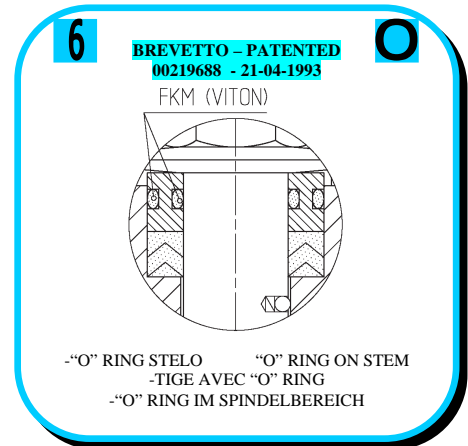
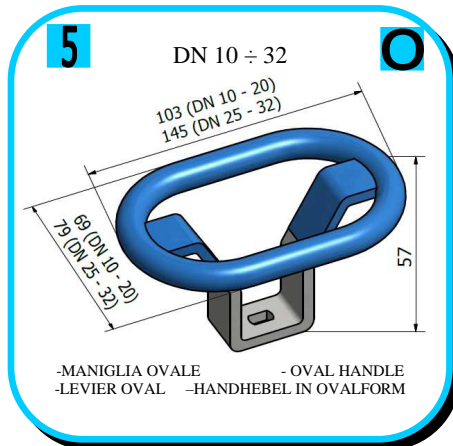
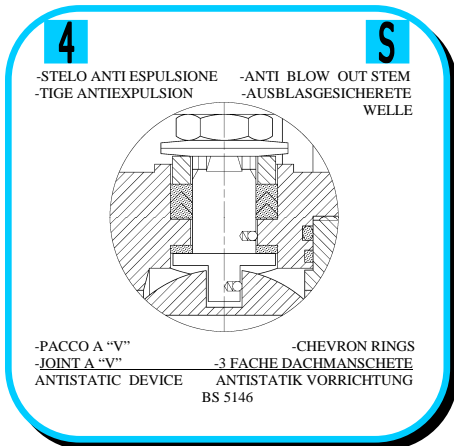
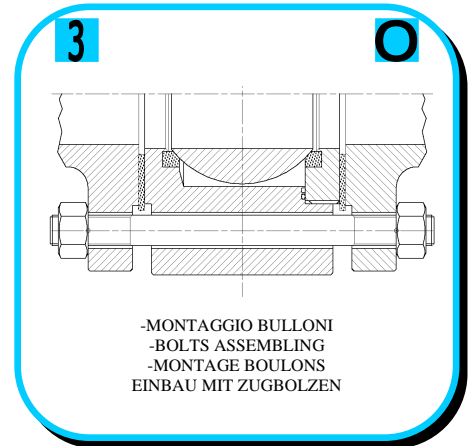
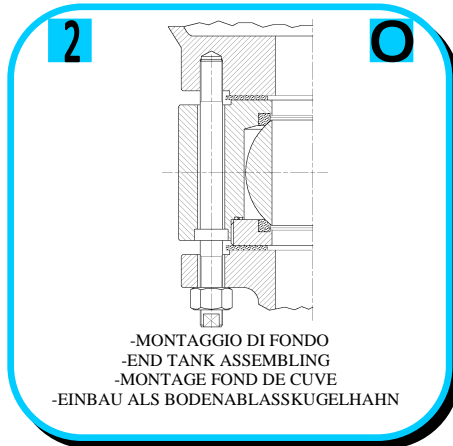
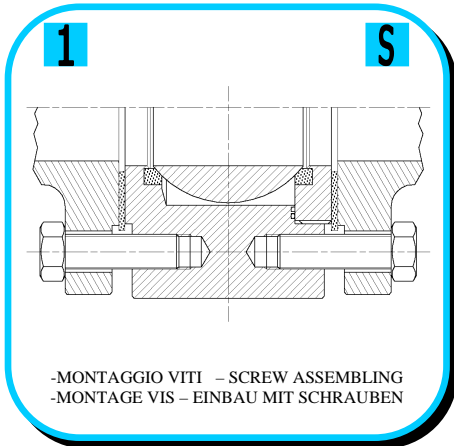

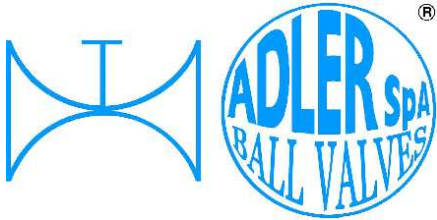

ISO 9001 by L.R.
 PED DIR. 2014/68/UE by L.R.
 ATEX DIR. 2014/34/UE by B.V.
 FIRE SAFE EXECUTION by L.R.
 ISO 15848 by TÜV
 ANTISTATIC DEVICE by L.R.
 FIRE SAFE TESTED ISO 10497 by L.R.
 EAC CERTIFICATION by B.V.

TYPE
FA1
 PN 10 ÷ 40
 ANSI 150 ÷ 300

7

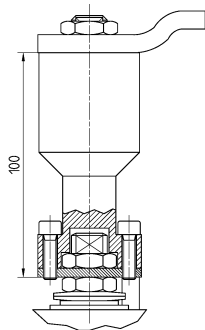

-PROLUNGA STELO -STEM EXTENSION
 -TIGE PROLONGEE -SPINDELVERLÄNGERUNG

8

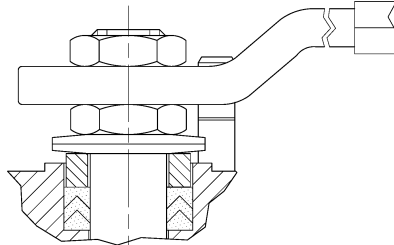

-PARTICOLARI INOX
 -STAINLESS STEEL DETAILS
 -ACCESSOIRES EN INOX
 -EDELSTAHLTEILE

9

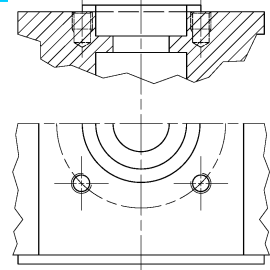

-ATTACCO "ISO" -"ISO" CONNECTIONS
 -SYSTEM "ISO" -ANSCHLUSS "ISO"

10

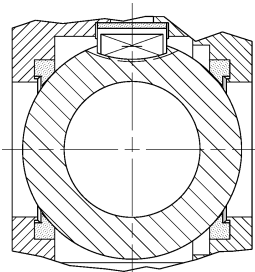

-SFERA CONTENUTA -CONTENTS BALL
 -BOULE CONTENUE
 -NICHT RAUSRAGENDE KUGEL

11

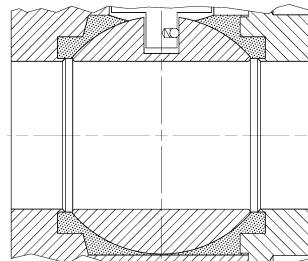

-TENUTE INTEGRALE -POCKETLESS SEATS
 -TENUE INTEGRALE -TOTRAUMARM
 -P.T.F.E. / R.T.F.E.

12

FIRE SAFE
 ISO 10497 "ISO-FT"
 (BS 6755 / API 607)



13

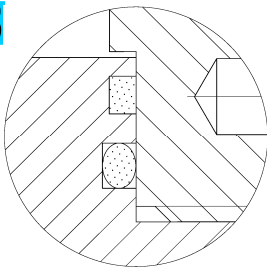

-DOPPIA TENUTA -DOUBLE SEALS
 -DOUBLE ETANCHEITE -DOPPELTE ABDICHTUNG
 -GHIERA A BATTUTA -METAL BEATING RING
 -EMBOUT AVEC BATTUE MECANIQUE
 -METALLISCHER ANSCHLAG DES
 GEWINDEDRÜCKRINGS

14

VEDERE / SEE ANSI B16.34

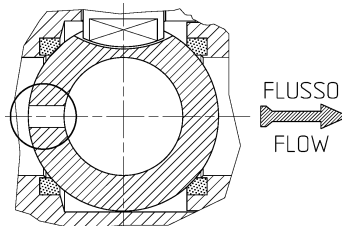

-FORO DI SCARICO NELLA SFERA
 -OVERPRESSURE HOLE INTO BALL
 -TROU DECOMPRESSION DANS LA BOULE
 -ENTLASTUNGSBOHRUNG IN DER KUGEL
 VALVOLA MONO DIREZIONALE
 MONO-DIRECTIONAL VALVE

15

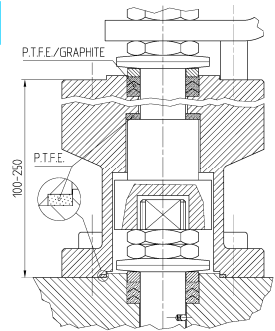

-SERVIZIO CRIOGENICO - CRYOGENIC SERVICE
 -SERVICE CRYOGENIQUE
 -TIEFTEMPORATUR SERVICE

16



-FIRE SAFE ISO FT+ "O" RING STELO
 -FIRE SAFE ISO FT+ "O" RING ON STEM
 -SECURITE FEU ISO FT+ TIGE AVEC "O" RING
 -FEUERSICHERE AUSFÜHRUNG ISO FT+
 "O" RING IM SPINDELBEREICH

ADLER

UNA GAMMA COMPLETA
 PRIVILEGIANDO LA QUALITA'

A COMPLETE RANGE PRIVILEGING
 THE QUALITY

18

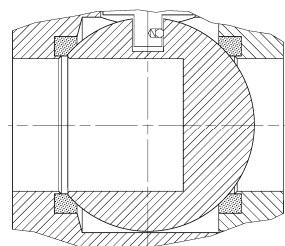

-SFERA CIECA PER CAMPIONATURA
 -BLIND BALL FOR SAMPLING
 -PRISE-ECHANTILLON
 KUGEL FÜR PROBENAHME

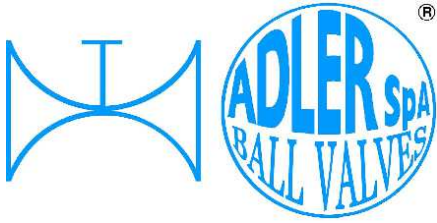

ISO 9001 by L.R.
 PED DIR. 2014/68/UE by L.R.
 ATEX DIR. 2014/34/UE by B.V.
 FIRE SAFE EXECUTION by L.R.
 ISO 15848 by TÜV
 ANTISTATIC DEVICE by L.R.
 FIRE SAFE TESTED ISO 10497 by L.R.
 EAC CERTIFICATION by B.V.

TYPE
FA1
 PN 10 ÷ 40
 ANSI 150 ÷ 300

VITI D'ASSEMBLAGGIO PER FA1 - ASSEMBLING SCREWS FOR FA1 - VIS D'ASSEMBLAGE POUR FA1- MONTAGESCHRAUBEN FÜR FA1

N° VITI - DIMENSIONE • N° SCREW - DIMENSIONS • N° VIS- DIMENSIONS • N° SCHRAUBEN-ABMESSUNGEN

EUROPEAN NORM

DN PN	10-15	20	25	32	40	50	65	80	100	125	150	200
16	8 M12 X30	8 M12 X30	8 M12 X30	8 M16 X35	8 M16 X35	8 M16 X40						
25	8 M12 X30	8 M12 X35	8 M12 X35	8 M16 X40	8 M16 X40	8 M16 X40						
40	8 M12 X30	8 M12 X35	8 M12 X35	8 M16 X40	8 M16 X40	8 M16 X40						

ANSI METRIC

(STANDARD ADLER)

Ø Rating	1/2"	3/4"	1"	1 1/4"	1 1/2"	2"	2 1/2"	3"	4"	5"	6"	8"
150	8 M14 X30	8 M14 X30	8 M14 X30	8 M14 X35	8 M14 X35	8 M16 X40						
300	8 M14 X30	8 M16 X30	8 M16 X35	8 M16 X40	8 M20 X45	16 M16 X40						

ANSI B1.1 UNC

(ON REQUEST)

Ø Rating	1/2"	3/4"	1"	1 1/4"	1 1/2"	2"	2 1/2"	3"	4"	5"	6"	8"
150	8 1/2 X 1 1/4	8 1/2 X 1 1/4	8 1/2 X 1 1/4	8 1/2 X 1 1/4	8 1/2 X 1 1/2	8 5/8 X 1 1/2						
300	8 1/2 X 1 1/4	8 5/8 X 1 1/4	8 5/8 X 1 1/2	8 5/8 X 1 1/2	8 3/4 X 1 3/4	16 5/8 X 1 3/4						

Length of screws calculated considering a gasket with thickness of 2mm.

