

ISO 9001 by L.R.  
PED DIR. 2014/68/UE by L.R.  
ATEX DIR. 2014/34/UE by B.V.  
FIRE SAFE EXECUTION BS6755/API 607 by L.R.  
FIRE SAFE TESTED ISO 10497 by L.R.  
ISO 15848 by TÜV  
ANTISTATIC DEVICE by L.R.  
EAC CERTIFICATION by B.V.

TYPE  
**FE2**  
ANSI 150

NORME E DIRETTIVE APPLICATE DISPONIBILI AL SEGUENTE LINK:  
STANDARD AND DIRECTIVE APPLIED AVAILABLE AT FOLLOWING LINK:  
[http://www.adlerspa.com/pdf/NORME\\_ADLER.pdf](http://www.adlerspa.com/pdf/NORME_ADLER.pdf)

## **VALVOLE A SFERA "ANSI B16.10" SPLIT BODY PASSAGGIO TOTALE**



ACTUATED  
BALL VALVES  
CERTIFIED  
SIL 3 Capable  
According to IEC 61508

FULL BORE ACCORDING  
TO ISO 14313

CONSTRUCTION ACCORDING TO:  
BS EN 12516-2 - ANSI B16.34  
ISO 14313 - ANSI B16.5  
ANSI B16.10/UNI EN 558-2

**BALL VALVES**  
**"ANSI B16.10" FULL BORE SPLIT BODY**  
**ROBINETS A BOISSEAU SPHERIQUE**  
**"ANSI B16.10" PASSAGE INTEGRAL 2 PIECES**  
**FLANSCHKUGELHÄHNE IN "ANSI B16.10"**  
**VOLLER DURCHGANG ZWEITEILIGES GEHÄUSE**

WEB SITE: [WWW.ADLERSPA.COM](http://WWW.ADLERSPA.COM)

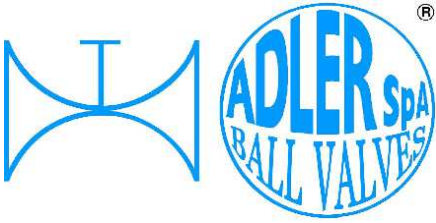

ISO 9001 by L.R.  
 PED DIR. 2014/68/UE by L.R.  
 ATEX DIR. 2014/34/UE by B.V.  
 FIRE SAFE EXECUTION BS6755/API 607 by L.R.  
 FIRE SAFE TESTED ISO 10497 by L.R.  
 ISO 15848 by TÜV  
 ANTISTATIC DEVICE by L.R.  
 EAC CERTIFICATION by B.V.

TYPE  
**FE2**  
 ANSI 150

VALVOLA A SFERA "ANSI B 16.10" SPLIT BODY PASSAGGIO TOTALE  
 BALL VALVES "ANSI B 16.10" SPLIT BODY FULL BORE  
 ROBINETS A BOISSEAU SPHERIQUE "ANSI B 16.10" PASSAGE INTEGRAL 2 PIECES  
 FLANSCHKUGELHÄHNE IN "ANSI B 16.10" VOLLER DURCHGANG ZWEIFTEILIGES GEHÄUSE

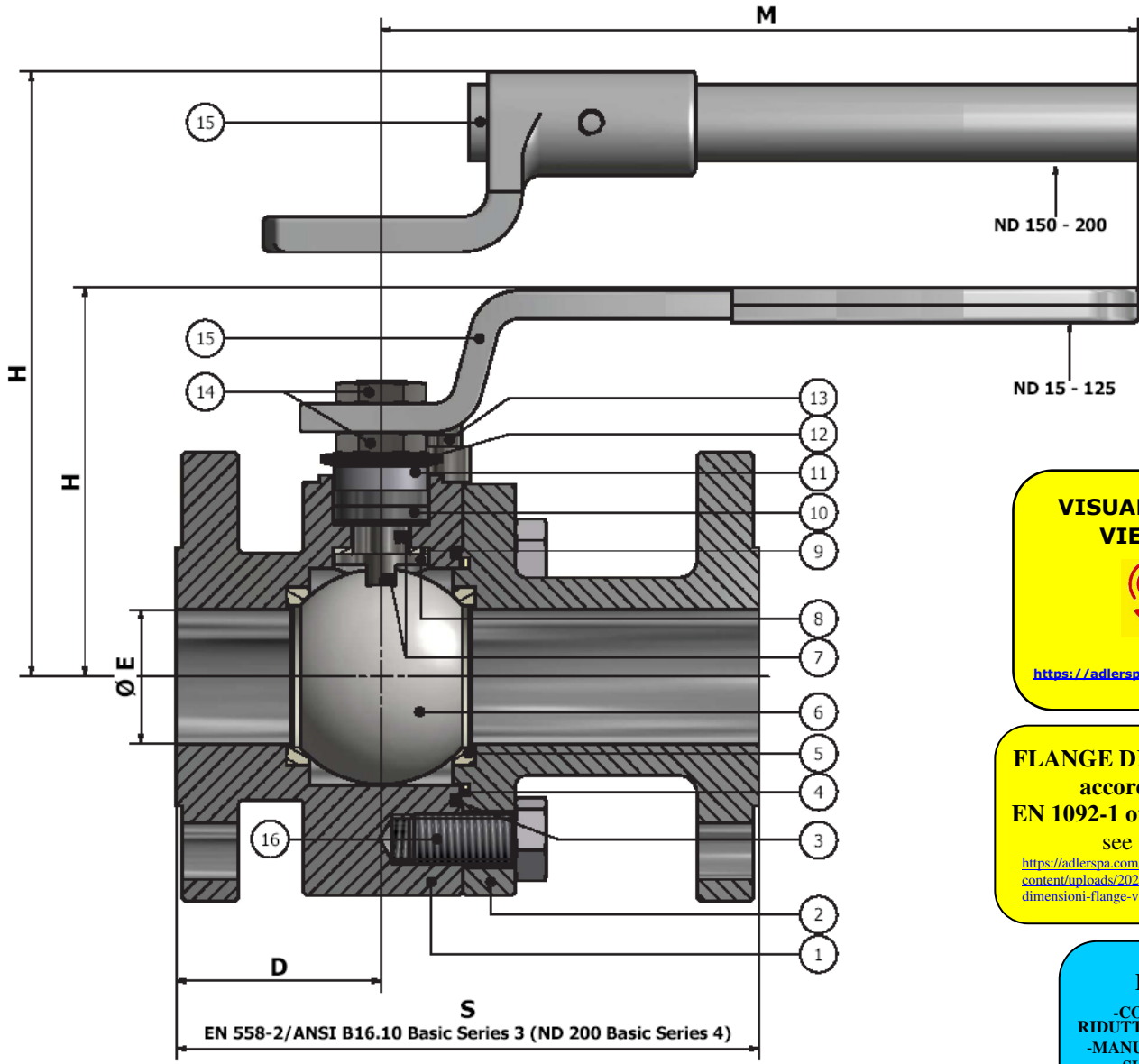

**VISUALIZZA 3D  
 VIEW 3D**

<https://adlerspa.com/prodotti/fe2>

**FLANGE DIMENSIONS**  
 according to  
 EN 1092-1 or ANSI B16.5  
 see table

<https://adlerspa.com/wp-content/uploads/2023/11/Tabella-dimensioni-flange-valvole-Adler.pdf>

**DN 200**  
 -CONSIGLIATO  
 RIDUTTORE MANUALE  
 -MANUAL GEAR BOX  
 SUGGESTED  
 -REDUCTEUR MANUEL  
 CONSEILLE  
 -EMPFEHLEN WIR EIN  
 HANDGETRIEBE

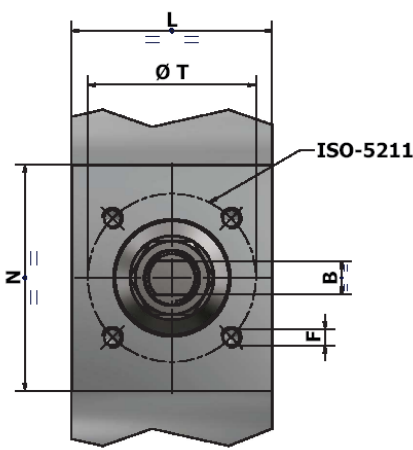
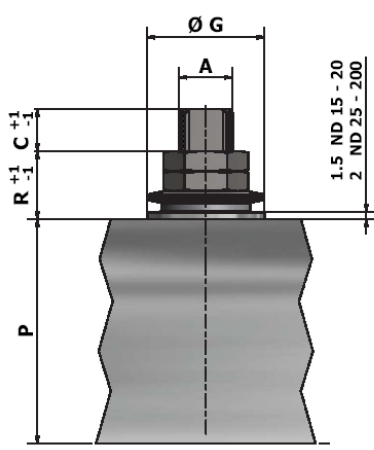



ISO 9001 by L.R.  
 PED DIR. 2014/68/UE by L.R.  
 ATEX DIR. 2014/34/UE by B.V.  
 FIRE SAFE EXECUTION BS6755/API 607 by L.R.  
 FIRE SAFE TESTED ISO 10497 by L.R.  
 ISO 15848 by TÜV  
 ANTISTATIC DEVICE by L.R.  
 EAC CERTIFICATION by B.V.

TYPE  
**FE2**  
 ANSI 150

N.	DESCRIZIONE DESCRIPTION BESCHREIBUNG	MATERIALI MATERIALS MATERIAUX WERKSTOFFE
1	CORPO BODY CORPS MITTE	ASTM A105 ASTM A479 304/304L ASTM A479 316/316L ASTM A 351 CF8M
2	LATERALE END LATERAL ENDE	ASTM A105 ASTM A479 304/304L ASTM A479 316/316L ASTM A 351 CF8M
3*	O-RING	FKM - (VITON)
4*	ANELLO SEAL ANNEAU DICHTUNGSRING	P.T.F.E.
5*	SEDE SEAT SIEGE SITZRING	P.T.F.E. R.P.T.F.E. (OPTIONAL)
6	SFERA BALL BOULE KUGEL	ASTM A479 304/304L ASTM A351 CF8 ASTM A479 316/316L ASTM A351 CF8M
7	DISPOSITIVO ANTISTATICO ANTISTATIC DEVICE CONTACT ANTISTATIQUE ANTISTATIK VORRICHTUNG	ASTM A479 316/316L
8	STELO STEM TIGE SPINDEL	ASTM A479 304/304L ASTM A479 316/316L

N.	DESCRIZIONE DESCRIPTION BESCHREIBUNG	MATERIALI MATERIALS MATERIAUX WERKSTOFFE
9*	BUSSOLA STEM SEAL JOINT TIGE UNTERE SPINDELABDICHTUNG	P.T.F.E.
10*	PACCO A "V" CHEVRON RINGS JOINT A "V" 3 FACHE DACHMANSCHETTE	P.T.F.E. / GRAFITE P.T.F.E. / GRAPHITE P.T.F.E. / GRAPHITE P.T.F.E. / GRAPHIT
11	PREMIBUSSOLA PRESSING BUSH PRESSE RONDELLE STOPFBUCHSDRUCKRING	ASTM A479 304
12	MOLLE A TAZZA SPRING WASHERS RONDELLES BELLEVILLE TELLERFEDERN	C72/50Cr V4 ZINCATO - GALVANIZED - ZINGUE - VERZINKT X10CrNi18.8 ON REQUEST
13	VITE DI FERMO E FERMO PIN AND STOP PIN PLONT ET PLOT D'ARRET ANSCHLAGBOLZEN	UNI3740 8.8 ZINCATO - GALVANIZED - ZINGUE - VERZINKT UNI 3951 A2-70 ON REQUEST
14	DADO - CONTRODADO NUT - LOCK NUT ECROU - CONTRE-ECROU MUTTER - KONTERMUTTER	UNI 3740 - 6S ZINCATO - GALVANIZED ZINGUE - VERZINKT ASTM A479 304 ON REQUEST
15	LEVA WRENCH LEVIER HANDHEBEL	AISI 1010 CHROMED FOR S.S. VALVES PAINTED FOR C.S. VALVES ASTM A479 304 ON REQUEST
16	VITE SCREW VIS SCHRAUBE	UNI 3740 8.8 ZINCATO - GALVANIZED - ZINGUE - VERZINKT UNI 3951 A2-70 ON REQUEST

\* RICAMBI CONSIGLIATI - RECOMMENDED SPARE PARTS - PIECES DE RECHANGE CONSEILLEES - ERSATZTEIL EMPFEHLUNG  
 ON REQUEST P.T.F.E. AVAILABLE CERTIFIED BAM, FDA, MOCA

**DIMENSIONI - DIMENSION - DIMENSIONS - ABMESSUNGEN**

DN	15	20	25	32	40	50	65	80	100	125	150	200	250	300
A	10	10	12	12	16	16	22	22	30	30	42	48		
B	6	6	8	8	10	10	14	14	18	18	28	32		
C	7	7	10	7	8	8	12	16	17	17	19	20		
D	46	48,5	49	52	58	76	72	75	77	100	117	155		
E	15	19	25	30	38	51	64	76	101	118	152	203		
F	M5	M5	M5	M5	M6	M6	M8	M8	M8	M10	M12	M16		
ISO	F03	F03	F03	F03	F05	F05	F07	F07	F07	F10	F12	F14		
G	25	25	25	25	35	35	55	55	55	70	85	100		
H	86	88	113	119	110	120	144	152	174	188	256	294		
L	33	33	33	35	45	54	62	62	64	92	129	176		
M	145	145	185	185	280	280	370	370	470	650	750	900		
N	33	39	43	55	57	64	67	65	70	97	109	123		
P	32,5	35	41	46,5	55	65	82	86	99,5	113,5	144	183		
R	8	8	17	17	20	20	23	23	26	26	34	36		
S	108	117	127	140	165	178	190	203	229	254	267	419		
T	36	36	36	36	50	50	70	70	70	102	125	140		
~Kg	2,7	3,6	4,5	6,2	9	14,3	21,5	25	34	56	91	159		
~Kg										48	67	121		

ASTM A105      ASTM A 351 CF8M

- DATI E CARATTERISTICHE SOGGETTI A VARIAZIONI SENZA PREAVVISO
- SPECIFICATIONS SUBJECT TO MODIFICATIONS WITHOUT PRIOR NOTICE
- TOUS DROITS DE MODIFICATION RESERVES
- KONSTRUKTIONÄNDERUNGEN VORBEHALTEN



ADLER SpA - BALL VALVES  
 20010 S. STEFANO TICINO (MI) ITALY V.le BORLETTI, 14 Tel. +39/02974842.11 FAX +39/0297271698  
 E-mail: [adler@adlerspa.com](mailto:adler@adlerspa.com) <http://www.adlerspa.com>

ADLER BALL VALVES FE2/22 RIPRODUZIONE VIETATA - COPYRIGHT

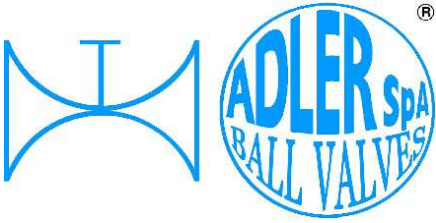

ISO 9001 by L.R.  
 PED DIR. 2014/68/UE by L.R.  
 ATEX DIR. 2014/34/UE by B.V.  
 FIRE SAFE EXECUTION BS6755/API 607 by L.R.  
 FIRE SAFE TESTED ISO 10497 by L.R.  
 ISO 15848 by TÜV  
 ANTISTATIC DEVICE by L.R.  
 EAC CERTIFICATION by B.V.

TYPE  
**FE2**  
 ANSI 150

• ESECUZIONI • EXECUTIONS • EXECUTIONS • AUSFÜHRUNGEN

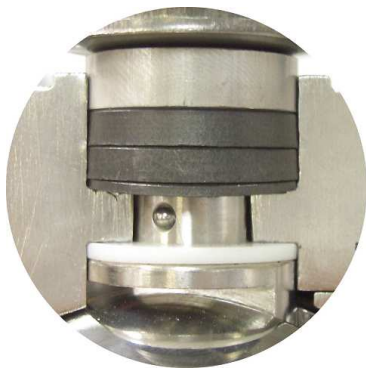

EXECUTION 4- 12

ONLY FOR VALVES  $\geq$  DN 50 **S**

FORO DI BILANCIAMENTO  
 BALANCING HOLE  
 TROU DE BALANCEMENT  
 DRUCKENTLASTUNGSBOHRUNG

ON REQUEST AVAILABLE ON DN  $\leq$  40



EXECUTION 6 - 16

**S** STANDARD

**O** OPTIONAL

**ANTISTATIC DEVICE CERTIFICATE**

ON REQUEST

**STAINLESS STEEL**  
 ASTM A479 304  
 DN 15 ÷ 125

ASTM A351 CF8  
 DN 150 ÷ 200

**3** **O**

**PN**  
**10 ÷ 40**

**4** **S**

-STELO ANTI ESPULSIONE -ANTI BLOW OUT STEM  
 -TIGE ANTIEXPULSION -AUSBLASGESICHERTE WELLE

-PACCO A "V" -CHEVRON RINGS  
 -JOINT A "V" -3 FACHE DACHMANSCHETE  
 ANTISTATIC DEVICE ANTISTATIK VORRICHTUNG  
 BS 5146

KEY TORQUE

**6** **O**

**BREVETTO - PATENTED**  
**00219688**

FKM (VITON)

-"O" RING STELO "O" RING ON STEM  
 -TIGE AVEC "O" RING  
 -"O" RING IM SPINDELBEREICH



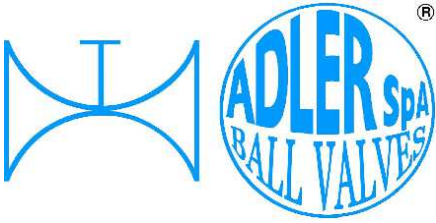

ISO 9001 by L.R.  
 PED DIR. 2014/68/UE by L.R.  
 ATEX DIR. 2014/34/UE by B.V.  
 FIRE SAFE EXECUTION BS6755/API 607 by L.R.  
 FIRE SAFE TESTED ISO 10497 by L.R.  
 ISO 15848 by TÜV  
 ANTISTATIC DEVICE by L.R.  
 EAC CERTIFICATION by B.V.

TYPE  
**FE2**  
 ANSI 150

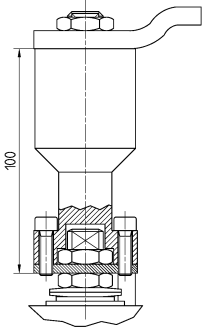
**7** 

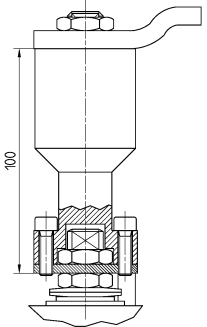

-PROLUNGA STELO -STEM EXTENSION  
 -TIGE PROLONGEE -SPINDELVERLÄNGERUNG

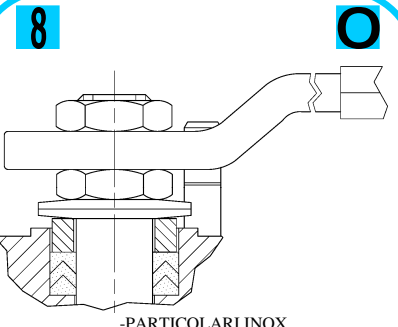
**8** 

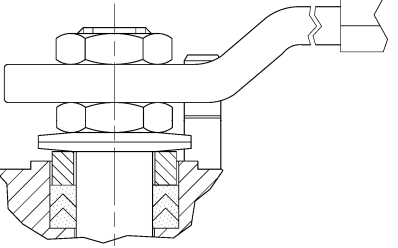

-PARTICOLARI INOX  
 -STAINLESS STEEL DETAILS  
 -ACCESSOIRES EN INOX  
 -EDELSTAHLTEILE

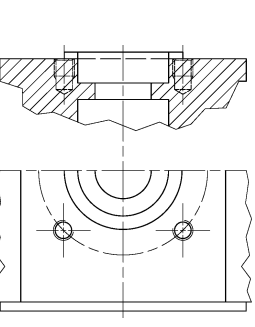
**9** 

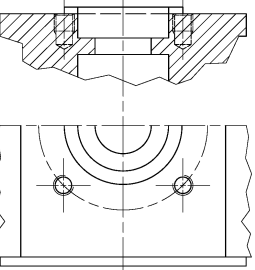

-ATTACCO "ISO" -"ISO" CONNECTIONS  
 -SYSTEM "ISO" -ANSCHLUSS "ISO"

**ADLER**

UNA GAMMA COMPLETA  
 PRIVILEGIANDO LA QUALITA'

A COMPLETE RANGE PRIVILEGING  
 THE QUALITY

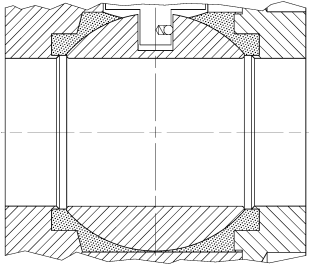
**11** 

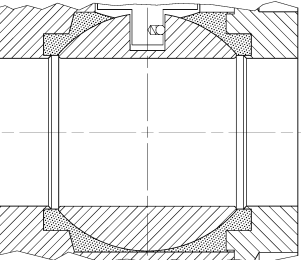

-TENUTE INTEGRALE -POCKETLESS SEATS  
 -TENUE INTEGRALE -TOTRAUMARM  
 -P.T.F.E. / R.T.F.E.

**12** 

FIRE SAFE  
 ISO 10497 "ISO-FT"  
 (BS 6755 / API 607)

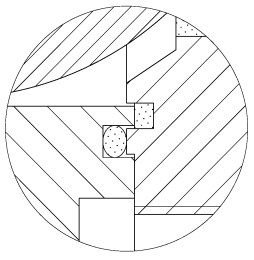

**13** 

BREVETTO - PATENTED  
 002/19619

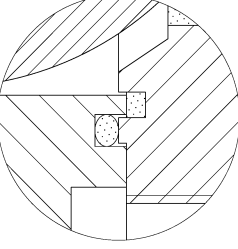

-DOPPIA TENUTA -DOUBLE SEALS  
 -DOUBLE ETANCHEITE -DOPPELTE ABDICHTUNG  
 -LATERALE A BATTUTA -METAL BEATING END  
 -LATERAL AVEC BATTUE MECANIQUE  
 -METALLISCHER ANSCHLAG DES  
 GEGENGEHÄUSES

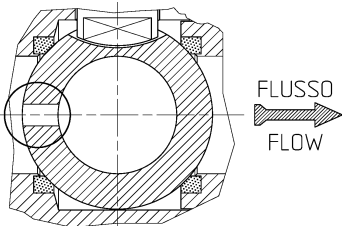
**14** 

VEDERE / SEE ANSI B16.34

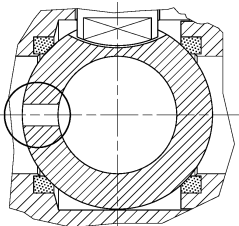

FLUSSO  
 FLOW

-FORO DI SCARICO NELLA SFERA  
 -OVERPRESSURE HOLE INTO BALL  
 -TROU DECOMPRESSION DANS LA BOULE  
 -ENTLASTUNGSBOHRUNG IN DER KUGEL  
 VALVOLA MONO DIREZIONALE  
 MONO-DIRECTIONAL VALVE

**15** 

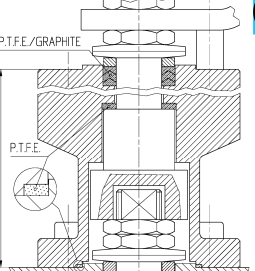

P.T.F.E./GRAPHITE  
 P.T.F.E.  
 100-250

-SERVIZIO CRIOGENICO - CRYOGENIC SERVICE  
 -SERVICE CRYOGENIQUE  
 -TIEFTEMPORATUR SERVICE

**16** 

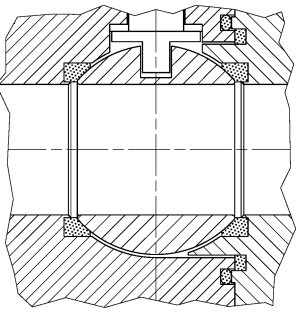

-FIRE SAFE ISO FT+ "O" RING STELO  
 -FIRE SAFE ISO FT+ "O" RING ON STEM  
 -SECURITE FEU ISO FT+ TIGE AVEC "O" RING  
 -FEUERSICHERE AUSFÜHRUNG ISO FT+  
 "O" RING IM SPINDELBEREICH

**17** 

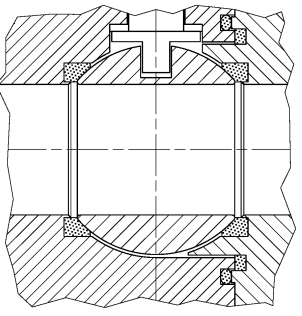

-TENUTA INTEGRALE METALLICA  
 -METALLIC POCKET LESS SEATS  
 -TENUE INTEGRALE METALLIQUE  
 -TOTRAUMARM METALLISCH

**ANTISTATIC DEVICE  
 CERTIFICATE**



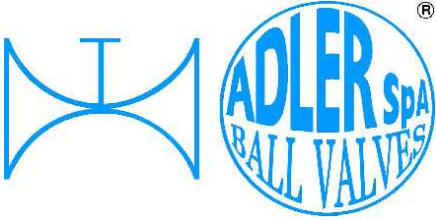

ISO 9001 by L.R.  
 PED DIR. 2014/68/UE by L.R.  
 ATEX DIR. 2014/34/UE by B.V.  
 FIRE SAFE EXECUTION BS6755/API 607 by L.R.  
 FIRE SAFE TESTED ISO 10497 by L.R.  
 ISO 15848 by TÜV  
 ANTISTATIC DEVICE by L.R.  
 EAC CERTIFICATION by B.V.

TYPE  
**FE2**  
 ANSI 150

**DIMENSIONI FLANGE - FLANGE DIMENSION - DIMENSIONS BRIDES - FLANSCHANSCHLUSSMASSE**

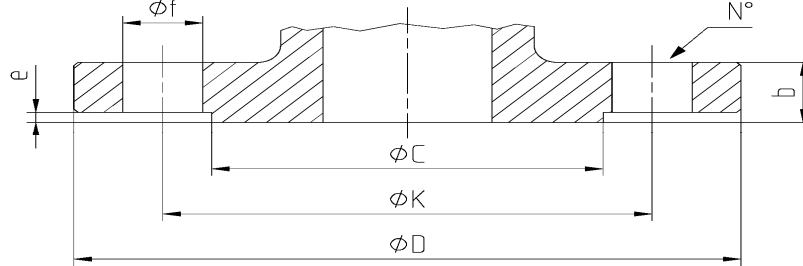

**ANSI B16.5**

DN	Ref.	1/2"	3/4"	1"	1 1/4"	1 1/2"	2"	2 1/2"	3"	4"	5"	6"	8"	10"	12"
ANSI 150 RF	D	88.9	98.6	108	117.4	127	152.4	177.8	190.5	228.6	254	279.4	342.9		
	C	35.1	43	50.8	63.5	92	104.7	127	157.3	185.7	215.9	269.8	269.8		
	K	6035	69.9	79.2	88.9	98.6	120.7	139.7	152.4	190.5	215.9	241.3	298.5		
	N°	4	4	4	4	4	4	4	4	8	8	8	8		
	f	15.8	15.8	15.8	15.8	19.1	19.1	19.1	19.1	19.1	22.4	22.4	22.4		
	b	11.2	12.7	14.3	15.8	17.6	19.1	22.4	23.9	23.9	23.9	25.4	28.5		
	e	1.6	1.6	1.6	1.6	1.6	1.6	1.6	1.6	1.6	1.6	1.6	1.6		

**EN 1092-1 (OPTIONAL)**

DN	Ref.	10	15	20	25	32	40	50	65	80	100	125	150	200	250	300	
PN 10	D	90	95	105	115	140	150	165	185	200	220	250	285	340			
	C	40	45	58	68	78	88	102	122	138	158	188	212	268			
	K	60	65	75	85	100	110	125	145	160	180	210	240	295			
	N°	4	4	4	4	4	4	4	4*	8	8	8	8	8			
	f	14	14	14	14	18	18	18	18	18	18	18	18	22	22		
	b	16	16	18	18	18	18	18	18	18	20	20	22	22	24		
	e	2	2	2	2	2	2	3	3	3	3	3	3	3	3		
PN 16	D	90	95	105	115	140	150	165	185	200	220	250	285	340			
	C	40	45	58	68	78	88	102	122	138	158	188	212	268			
	K	60	65	75	85	100	110	125	145	160	180	210	240	295			
	N°	4	4	4	4	4	4	4	4*	8	8	8	8	12			
	F	14	14	14	14	18	18	18	18	18	18	18	18	22	22		
	b	16	16	18	18	18	18	18	18	18	20	20	22	22	24		
	e	2	2	2	2	2	2	3	3	3	3	3	3	3	3		
PN 25	D	90	95	105	115	140	150	165	185	200	235	270	300	360			
	C	40	45	58	68	78	88	102	122	138	162	188	218	278			
	K	60	65	75	85	100	110	125	145	160	190	220	250	310			
	N°	4	4	4	4	4	4	4	8	8	8	8	8	12			
	f	14	14	14	14	18	18	18	18	18	22	26	26	26			
	b	16	16	18	18	18	18	20	22	24	24	26	28	30			
	e	2	2	2	2	2	2	3	3	3	3	3	3	3			
PN 40	D	90	95	105	115	140	150	165	185	200	235	270	300	375			
	C	40	45	58	68	78	88	102	122	138	162	188	218	285			
	K	60	65	75	85	100	110	125	145	160	190	220	250	320			
	N°	4	4	4	4	4	4	4	8	8	8	8	8	12			
	f	14	14	14	14	18	18	18	18	18	22	26	26	30			
	b	16	16	18	18	18	18	20	22	24	24	26	28	34			
	e	2	2	2	2	2	2	3	3	3	3	3	3	3			

\* n°8 fori