



ISO 9001 by L.R.
PED DIR. 2014/68/UE by L.R.
ATEX DIR. 2014/34/UE by B.V.
FIRE SAFE EXECUTION by L.R.
ISO 15848 by TÜV
ANTISTATIC DEVICE by L.R.
FIRE SAFE TESTED ISO 10497 by L.R.
EAC CERTIFICATION by B.V.

TYPE
FJ2
PN 10 ÷ 40

NORME E DIRETTIVE APPLICATE DISPONIBILI AL SEGUENTE LINK:
STANDARD AND DIRECTIVE APPLIED AVAILABLE AT FOLLOWING LINK:
http://www.adlerspa.com/pdf/NORME_ADLER.pdf

VALVOLE A SFERA "UNI EN 558-1" SPLIT BODY PASSAGGIO TOTALE CON CAMICIA DI RISCALDAMENTO

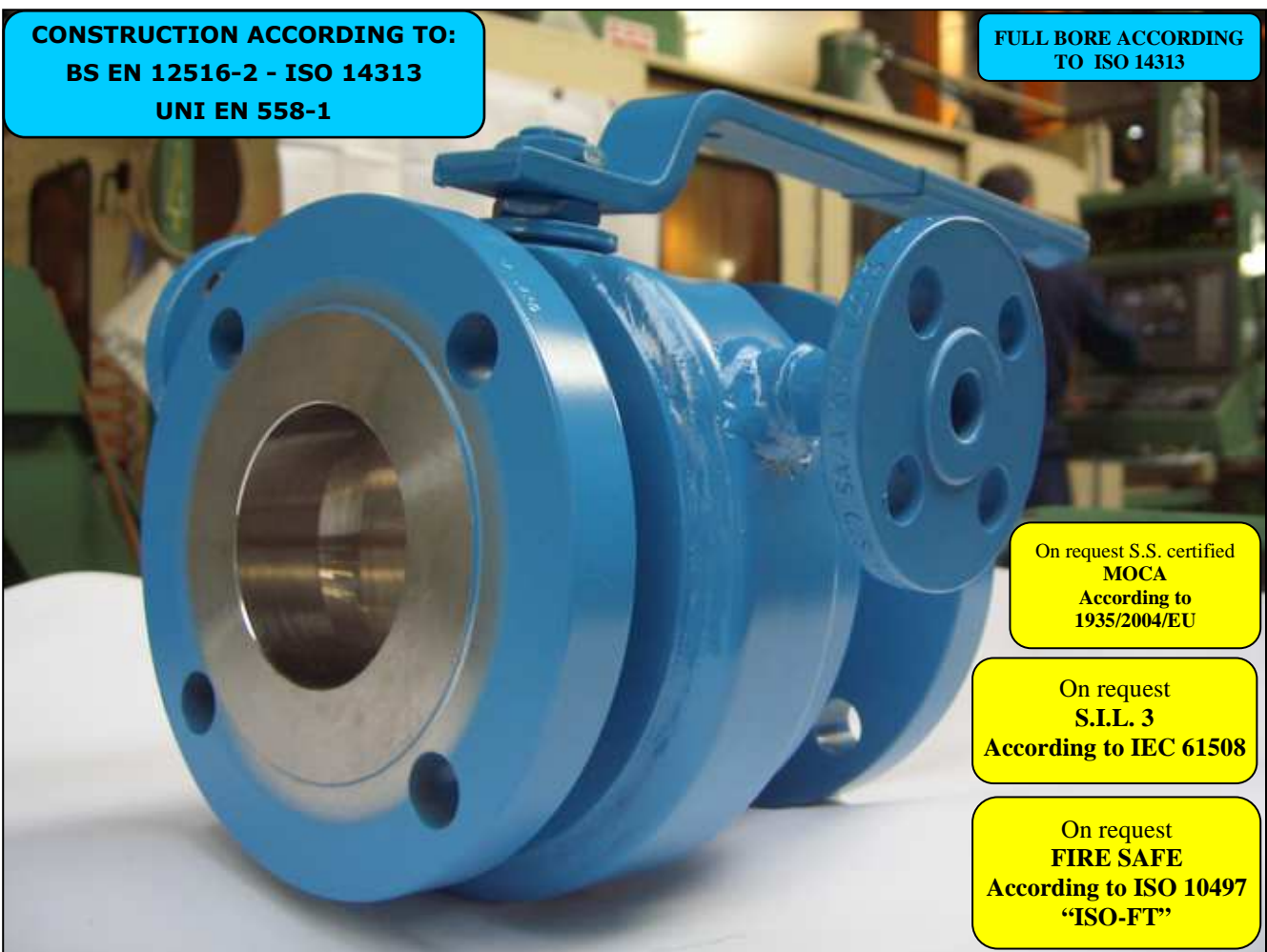

BALL VALVES
"UNI EN 558-1" FULL BORE SPLIT BODY WITH HEATING JACKET
ROBINETS A BOISSEAU SPHERIQUE
"UNI EN 558-1" PASSAGE INTEGRAL 2 PIECES AVEC ENVELOPPE
FLANSCHKUGELHÄHNE IN "UNI EN 558-1"
VOLLER DURCHGANG ZWEITEILIGES GEHÄUSE MIT HEIZMANTEL

WEB SITE: WWW.ADLERSPA.COM



ISO 9001 by L.R.
 PED DIR. 2014/68/UE by L.R.
 ATEX DIR. 2014/34/UE by B.V.
 FIRE SAFE EXECUTION by L.R.
 ISO 15848 by TÜV
 ANTISTATIC DEVICE by L.R.
 FIRE SAFE TESTED ISO 10497 by L.R.
 EAC CERTIFICATION by B.V.

TYPE
FJ2
 PN 10 ÷ 40

VALVOLA A SFERA "UNI EN 558-1" SPLIT BODY PASSAGGIO TOTALE CON CAMICIA DI RISCALDAMENTO
 BALL VALVES "UNI EN 558-1" SPLIT BODY FULL BORE WITH HEATING JACKET
 ROBINETS A BOISSEAU SPHERIQUE "UNI EN 558-1" PASSAGE INTEGRAL 2 PIECES AVEC ENVELOPPE
 FLANSCHKUGELHÄHNE IN "UNI EN 558-1" VOLLER DURCHGANG ZWEIFTEILIGES GEHÄUSE MIT HEIZMANTEL

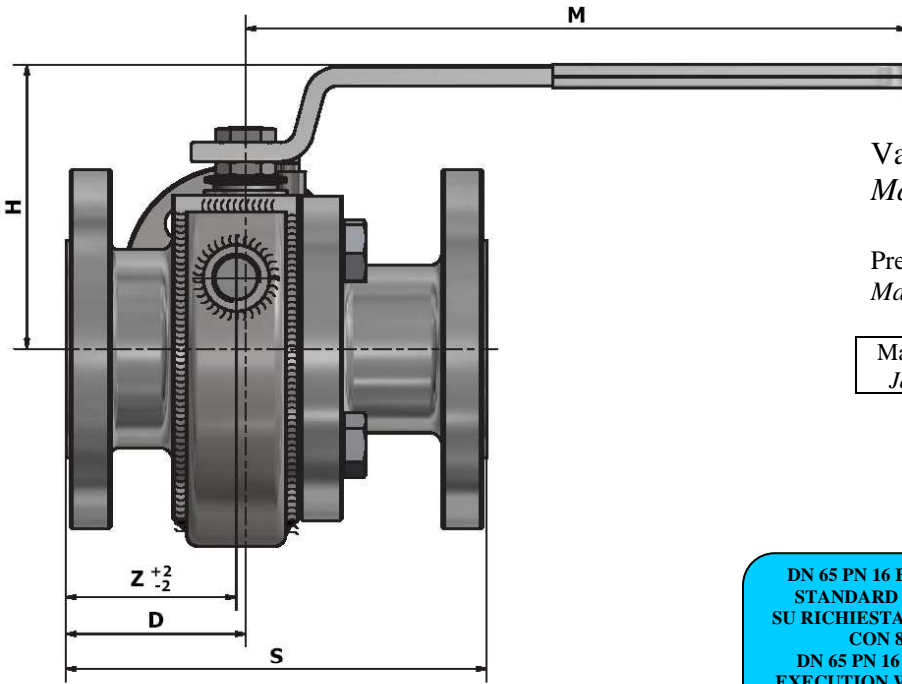

Valvola base FM2
 Main Ball Valve FM2

Pressione massima di lavoro nelle camicie 10 bar
 Maximum working pressure for jacket 10 bar

Materiale camicia	CARBON STEEL (STANDARD)
Jacket material	STAINLESS STEEL (OPTIONAL)

DN 65 PN 16 ESECUZIONE STANDARD CON 4 FORI
 SU RICHIESTA DISPONIBILE CON 8 FORI
 DN 65 PN 16 STANDARD EXECUTION WITH 4 HOLES
 ON REQUEST AVAILABLE WITH 8 HOLES

**VISUALIZZA 3D
 VIEW 3D**

<https://adlerspa.com/prodotti/fj2>

DN 200 ÷ 300
 -CONSIGLIATO RIDUTTORE MANUALE SUGGERED
 -MANUAL GEAR BOX SUGGESTED
 -REDUCTEUR MANUEL CONSEILLE
 -EMPFEHLEN WIR EIN HANDGETRIEBE

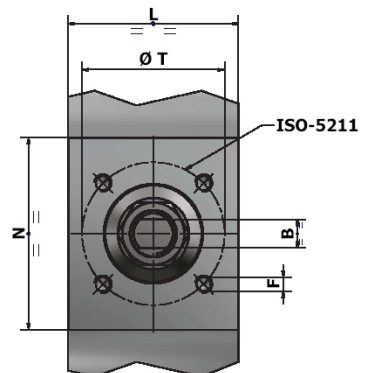
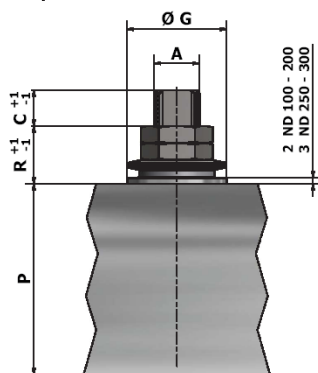
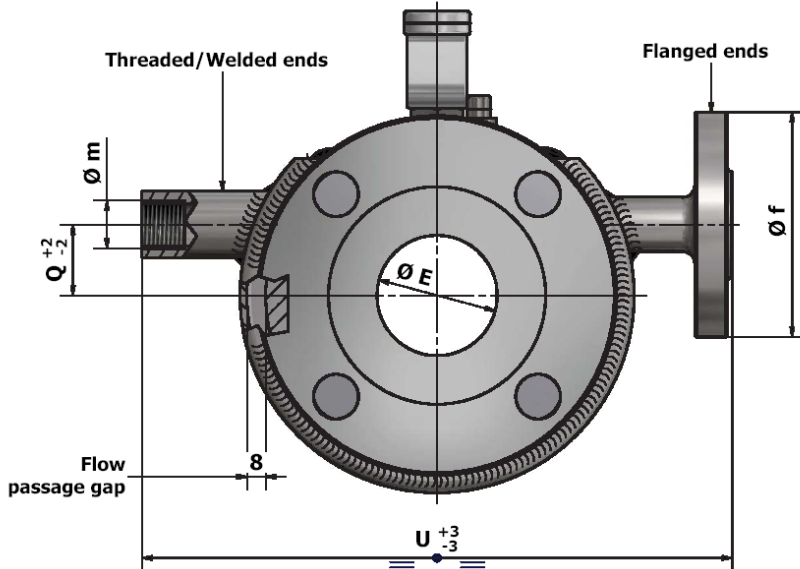



ISO 9001 by L.R.
 PED DIR. 2014/68/UE by L.R.
 ATEX DIR. 2014/34/UE by B.V.
 FIRE SAFE EXECUTION by L.R.
 ISO 15848 by TÜV
 ANTISTATIC DEVICE by L.R.
 FIRE SAFE TESTED ISO 10497 by L.R.
 EAC CERTIFICATION by B.V.

TYPE
FJ2
 PN 10 ÷ 40

N.	DESCRIZIONE DESCRIPTION DESCRIPTION BESCHREIBUNG	MATERIALI MATERIALS MATERIAUX WERKSTOFFE
1	CORPO BODY CORPS MITTE	ASTM A105 ASTM A479 304/304L ASTM A479 316/316L ASTM A 351 CF8M
2	LATERALE END LATERAL ENDE	ASTM A105 ASTM A479 304/304L ASTM A479 316/316L ASTM A 351 CF8M
3*	O-RING	FKM - (VITON)
4*	ANELLO SEAL ANNEAU DICHTUNGSRING	P.T.F.E.
5*	SEDE SEAT SIEGE SITZRING	P.T.F.E. + 15% FIBERGLASS
6	SFERA BALL BOULE KUGEL	ASTM A479 304/304L ASTM A351 CF8 ASTM A479 316/316L ASTM A351 CF8M
7	DISPOSITIVO ANTISTATICO ANTISTATIC DEVICE CONTACT ANTISTATIQUE ANTISTATIK VORRICHTUNG	ASTM A479 316/316L
8	STELO STEM TIGE SPINDEL	ASTM A479 304/304L ASTM A479 316/316L

N.	DESCRIZIONE DESCRIPTION DESCRIPTION BESCHREIBUNG	MATERIALI MATERIALS MATERIAUX WERKSTOFFE
9*	BUSSOLA STEM SEAL JOINT TIGE UNTERE SPINDELABDICHTUNG	P.T.F.E.
10*	PACCO A "V" CHEVRON RINGS JOINT A "V" 3 FACHE DACHMANSCHETTE	P.T.F.E. / GRAFITE P.T.F.E. / GRAPHITE P.T.F.E. / GRAPHITE P.T.F.E. / GRAPHIT
11	PREMIBUSSOLA PRESSING BUSH PRESSE RONDELLE STOPFBUCHSDRUCKRING	ASTM A479 304
12	MOLLE A TAZZA SPRING WASHERS RONDELLES BELLEVILLE TELLERFEDERN	C72/50Cr V4 ZINCATO - GALVANIZED - X10CrNi18.8 ZINGUE - VERZINKT ON REQUEST
13	VITE DI FERMO E FERMO PIN AND STOP PIN PLONT ET PLOT D'ARRET ANSCHLAGBOLZEN	UNI 3740 8.8 ZINCATO - GALVANIZED - UNI 3951 A2-70 ZINGUE - VERZINKT ON REQUEST
14	DADO - CONTRODADO NUT - LOCK NUT ECROU - CONTRE-ECROU MUTTER - KONTERMUTTER	UNI 3740 - 6S ZINCATO - GALVANIZED ASTM A479 304 ZINGUE - VERZINKT ON REQUEST
15	LEVA WRENCH LEVIER HANDHEBEL	AISI 1010 CHROMED FOR S.S. VALVES ASTM A479 304 PAINTED FOR C.S. VALVES ON REQUEST
16	VITE SCREW VIS SCHRAUBE	UNI 3740 8.8 ZINCATO - GALVANIZED - UNI 3951 A2-70 ZINGUE - VERZINKT ON REQUEST

* RICAMBI CONSIGLIATI - RECOMMENDED SPARE PARTS - PIECES DE RECHANGE CONSEILLEES - ERSATZTEIL EMPFEHLUNG
 ON REQUEST P.T.F.E. AVAILABLE CERTIFIED BAM, FDA, MOCA

DIMENSIONI - DIMENSION - DIMENSIONS - ABMESSUNGEN

DN	15	20	25	32	40	50	65	80	100	125	150	200	250	300
A	10	10	12	12	16	16	22	22	30	30	42	48	56	56
B	6	6	8	8	10	10	14	14	18	18	28	32	36	36
C	7	7	10	10	10	10	12	12	16,5	16,5	19	20	20	20
D	49	51,5	50	51,5	59	61,5	70,5	73	85	100	144	180.5	196	237
D											117	155		
E	15	19	25	30	38	51	64	76	101	118	152	203	254	305
F	M5	M5	M5	M5	M6	M6	M8	M8	M8	M10	M12	M16	M20	M20
f	DN 15 PN 16							DN 25 PN 16						
ISO	F03	F03	F03	F03	F05	F05	F07	F07	F07	F10	F12	F14	F16	F16
G	25	25	25	25	35	35	55	55	55	70	85	100	130	130
H	86	88	113	119	110	120	144	152	174	188	256	294	343	381
L	35	35	35	35	46,5	46,5	64,5	64,5	72	93	111	130	153	153
M	145	145	185	185	280	280	370	370	470	650	750	900	1000	1000
m	Ø1/2" GAS							Ø1" GAS						
N	58	58	58	58	72,5	72,5	90	90	70	97	108	126	153	153
P	33,7	36	49,3	54,8	64,8	74,8	93,5	102	99,5	119	144	183	220	258,5
Q	/	/	/	25	30	30	45	50	70	80	95	130	160	190
R	7	7	9	9	10	10	11	11	26	26	34	37	45	45
S	115	120	125	130	140	150	170	180	190	325	350	400	450	500
T	36	36	36	36	50	50	70	70	70	102	125	140	165	165
U	170	180	190	210	230	250	270	300	340	360	420	500	600	650
Z	49	51,5	51	53	60	62	72	74	85	100	144	180	196	237
Kg	4	5	6,5	8,5	11,5	15	23	28	33	63	100	161	220	260
Kg										52	74	125	180	205

- DATI E CARATTERISTICHE SOGGETTI A VARIAZIONI SENZA PREAVVISO
- SPECIFICATIONS SUBJECT TO MODIFICATIONS WITHOUT PRIOR NOTICE
- TOUS DROITS DE MODIFICATION RESERVES
- KONSTRUKTIONSÄNDERUNGEN VORBEHALTEN

ASTM A105

ASTM A 351 CF8M



ADLER SpA - BALL VALVES
 20010 S. STEFANO TICINO (MI) ITALY V.le BORLETTI, 14 Tel. +39/02974842.11 FAX +39/0297271698
 E-mail: adler@adlerspa.com <http://www.adlerspa.com>



ISO 9001 by L.R.
 PED DIR. 2014/68/UE by L.R.
 ATEX DIR. 2014/34/UE by B.V.
 FIRE SAFE EXECUTION by L.R.
 ISO 15848 by TÜV
 ANTISTATIC DEVICE by L.R.
 FIRE SAFE TESTED ISO 10497 by L.R.
 EAC CERTIFICATION by B.V.

TYPE
FJ2
 PN 10 ÷ 40

• ESECUZIONI • EXECUTIONS • EXECUTIONS • AUSFÜHRUNGEN



EXECUTION 4-12

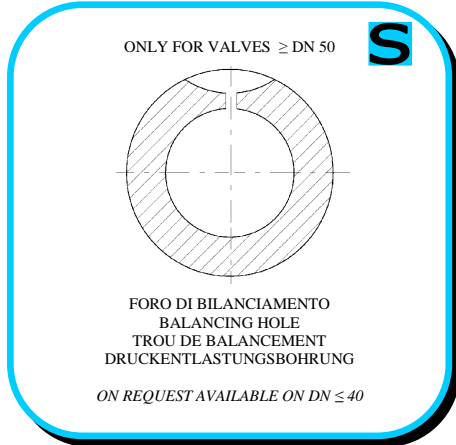

EXECUTION 6-16

S STANDARD

O OPTIONAL

1 **S**

CARBON STEEL

ASTM A105
 DN 15 ÷ 300

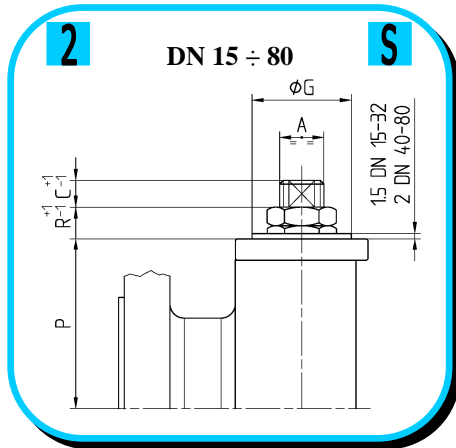

3 **S**

STAINLESS STEEL
 ASTM A479 316/316L
 DN 15 ÷ 125

ASTM A351 CF8M
 DN 150 ÷ 300

4 **S**

-STELO ANTI ESPULSIONE -ANTI BLOW OUT STEM
 -TIGE ANTIEXPULSION -AUSBLASGESICHERETE WELLE

-PACCO A "V" -CHEVRON RINGS
 -JOINT A "V" -3 FACHE DACHMANSCHETE
 ANTISTATIC DEVICE ANTISTATIK VORRICHTUNG
 BS 5146

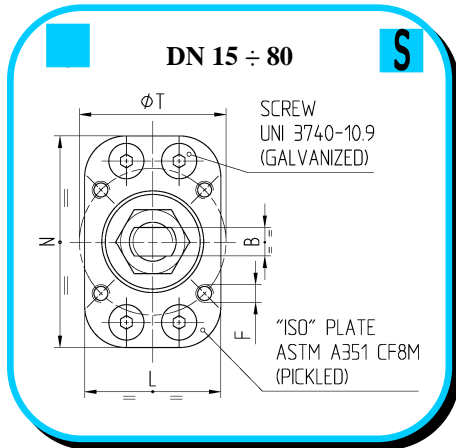

6 **O**

BREVETTO - PATENTED
 00219688 - 21-04-1993

FKM (VITON)

-"O" RING STELO "O" RING ON STEM
 -TIGE AVEC "O" RING
 -"O" RING IM SPINDELBEREICH

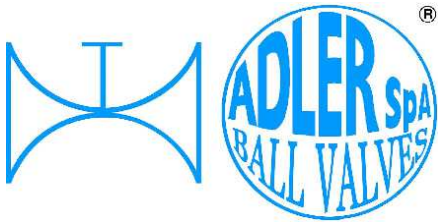

ISO 9001 by L.R.
 PED DIR. 2014/68/UE by L.R.
 ATEX DIR. 2014/34/UE by B.V.
 FIRE SAFE EXECUTION by L.R.
 ISO 15848 by TÜV
 ANTISTATIC DEVICE by L.R.
 FIRE SAFE TESTED ISO 10497 by L.R.
 EAC CERTIFICATION by B.V.

TYPE
FJ2
 PN 10 ÷ 40

7

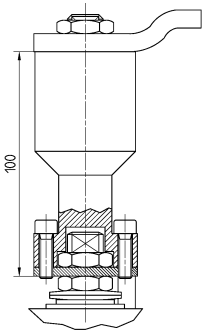

-PROLUNGA STELO -STEM EXTENSION
 -TIGE PROLONGEE -SPINDELVERLÄNGERUNG

8

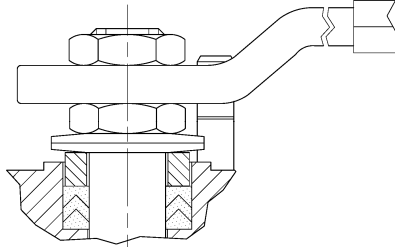

-PARTICOLARI INOX
 -STAINLESS STEEL DETAILS
 -ACCESSOIRES EN INOX
 -EDELSTAHLTEILE

9

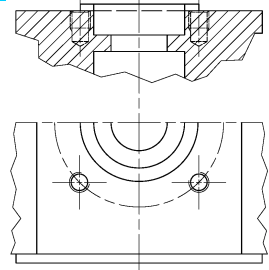

-ATTACCO "ISO" -"ISO" CONNECTIONS
 -SYSTEM "ISO" -ANSCHLUSS "ISO"

**GEAR BOX
 AG series**



11

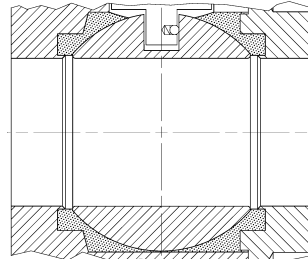

-TENUTE INTEGRALE -POCKETLESS SEATS
 -TENUCE INTEGRALE -TOTRAUMARM
 -P.T.F.E. / R.T.F.E.

12

FIRE SAFE
 ISO 10497 "ISO-FT"
 (BS 6755 / API 607)



13

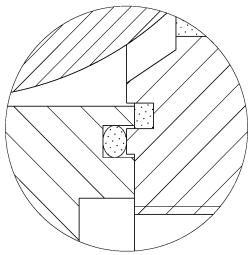

BREVETTO - PATENTED
 002/19619

-DOPPIA TENUTA -DOUBLE SEALS
 -DOUBLE ETANCHEITE -DOPPELTE ABDICHTUNG
 -LATERALE A BATTUTA -METAL BEATING END
 -LATERAL AVEC BATTUE MECANIQUE
 -METALLISCHER ANSCHLAG DES
 GEGENGEHÄUSES

14

VEDERE / SEE ANSI B16.34

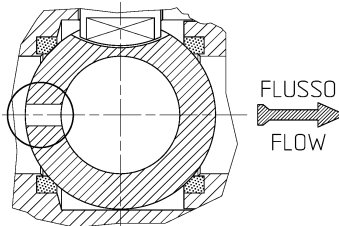

FLUSSO
 FLOW

-FORO DI SCARICO NELLA SFERA
 -OVERPRESSURE HOLE INTO BALL
 -TROU DECOMPRESSION DANS LA BOULE
 -ENTLASTUNGSBOHRUNG IN DER KUGEL
 VALVOLA MONO DIREZIONALE
 MONO-DIRECTIONAL VALVE

**AQUILA - EAGLE - AIGLE
 ADLER**



16



-FIRE SAFE ISO FT+ "O" RING STELO
 -FIRE SAFE ISO FT+ "O" RING ON STEM
 -SECURITE FEU ISO FT+ TIGE AVEC "O" RING
 -FEUERSICHERE AUSFÜHRUNG ISO FT+
 "O" RING IM SPINDELBEREICH

17

-TENUTA INTEGRALE METALLICA
 -METALLIC POCKET LESS SEATS
 -TENUCE INTEGRALE METALLIQUE
 -TOTRAUMARM METALLISCH

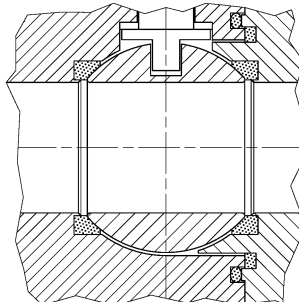

ADLER

UNA GAMMA COMPLETA
 PRIVILEGIANDO LA QUALITA'
 A COMPLETE RANGE PRIVILEGING
 THE QUALITY

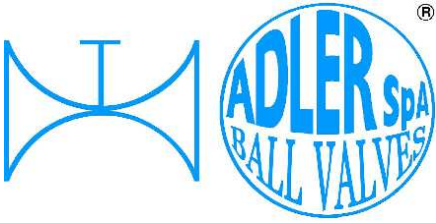

ISO 9001 by L.R.
 PED DIR. 2014/68/UE by L.R.
 ATEX DIR. 2014/34/UE by B.V.
 FIRE SAFE EXECUTION by L.R.
 ISO 15848 by TÜV
 ANTISTATIC DEVICE by L.R.
 FIRE SAFE TESTED ISO 10497 by L.R.
 EAC CERTIFICATION by B.V.

TYPE
FJ2
 PN 10 ÷ 40

DIMENSIONI FLANGE - FLANGE DIMENSION - DIMENSIONS BRIDES - FLANSCHANSCHLUSSMASSE

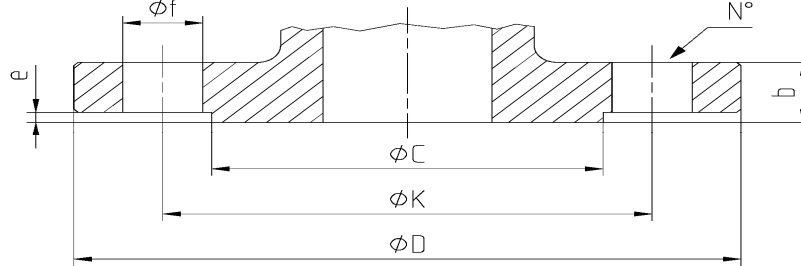

DN	Ref.	10	15	20	25	32	40	50	65	80	100	125	150	200	250	300	
PN 10	D		95	105	115	140	150	165	185	200	220	250	285	340	395	445	
	C		45	58	68	78	88	102	122	138	158	188	212	268	320	370	
	K		65	75	85	100	110	125	145	160	180	210	240	295	350	400	
	N°		4	4	4	4	4	4	4	4*	8	8	8	8	8	12	12
	f		14	14	14	18	18	18	18	18	18	18	18	22	22	22	22
	b		16	18	18	18	18	18	18	18	20	20	22	22	24	26	26
PN 16	D		95	105	115	140	150	165	185	200	220	250	285	340	405	460	
	C		45	58	68	78	88	102	122	138	158	188	212	268	320	378	
	K		65	75	85	100	110	125	145	160	180	210	240	295	355	410	
	N°		4	4	4	4	4	4	4	4*	8	8	8	8	12	12	12
	F		14	14	14	18	18	18	18	18	18	18	18	22	22	26	26
	b		16	18	18	18	18	18	18	18	20	20	22	22	24	26	28
PN 25	D		95	105	115	140	150	165	185	200	235	270	300	360	425	485	
	C		45	58	68	78	88	102	122	138	162	188	218	278	335	395	
	K		65	75	85	100	110	125	145	160	190	220	250	310	370	430	
	N°		4	4	4	4	4	4	4	8	8	8	8	8	12	12	16
	f		14	14	14	18	18	18	18	18	22	26	26	26	30	30	
	b		16	18	18	18	18	20	22	24	24	26	28	30	32	34	
PN 40	D		95	105	115	140	150	165	185	200	235	270	300	375	450	515	
	C		45	58	68	78	88	102	122	138	162	188	218	285	345	410	
	K		65	75	85	100	110	125	145	160	190	220	250	320	385	450	
	N°		4	4	4	4	4	4	4	8	8	8	8	12	12	16	
	f		14	14	14	18	18	18	18	18	22	26	26	30	33	33	
	b		16	18	18	18	18	20	22	24	24	26	28	34	38	42	
PN 40	D		95	105	115	140	150	165	185	200	235	270	300	375	450	515	
	C		45	58	68	78	88	102	122	138	162	188	218	285	345	410	
	K		65	75	85	100	110	125	145	160	190	220	250	320	385	450	
	N°		4	4	4	4	4	4	4	8	8	8	8	12	12	16	
	f		14	14	14	18	18	18	18	18	22	26	26	30	33	33	
	b		16	18	18	18	18	20	22	24	24	26	28	34	38	42	
PN 40	D		95	105	115	140	150	165	185	200	235	270	300	375	450	515	
	C		45	58	68	78	88	102	122	138	162	188	218	285	345	410	
	K		65	75	85	100	110	125	145	160	190	220	250	320	385	450	
	N°		4	4	4	4	4	4	4	8	8	8	8	12	12	16	
	f		14	14	14	18	18	18	18	18	22	26	26	30	33	33	
	b		16	18	18	18	18	20	22	24	24	26	28	34	38	42	
PN 40	D		95	105	115	140	150	165	185	200	235	270	300	375	450	515	
	C		45	58	68	78	88	102	122	138	162	188	218	285	345	410	
	K		65	75	85	100	110	125	145	160	190	220	250	320	385	450	
	N°		4	4	4	4	4	4	4	8	8	8	8	12	12	16	
	f		14	14	14	18	18	18	18	18	22	26	26	30	33	33	
	b		16	18	18	18	18	20	22	24	24	26	28	34	38	42	

