

ISO 9001 by L.R.
PED DIR. 2014/68/UE by L.R.
ATEX DIR. 2014/34/UE by B.V.
FIRE SAFE EXECUTION BS6755/API 607 by L.R.
FIRE SAFE TESTED ISO 10497 by L.R.
ISO 15848 by TÜV
ANTISTATIC DEVICE by L.R.
EAC CERTIFICATION by B.V.

TYPE
FP3
PN 20 ÷ 100

NORME E DIRETTIVE APPLICATE DISPONIBILI AL SEGUENTE LINK:
STANDARD AND DIRECTIVE APPLIED AVAILABLE AT FOLLOWING LINK:
http://www.adlerspa.com/pdf/NORME_ADLER.pdf

VALVOLE A SFERA "3 PEZZI" PASSAGGIO TOTALE EN 10226-1 (EX ISO 7-1 Rp) – ANSI B1.20.1 NPT – S.W. – B.W.



On request
TPED 2010/35/UE
FROM ND 1/2" TO ND 2"
PN 40

ACTUATED
BALL VALVES
CERTIFIED
SIL 3 Capable
According to IEC 61508

FULL BORE ACCORDING
TO ISO 14313

CONSTRUCTION ACCORDING TO:
BS EN 12516-2 - DIN 3202 M3
ISO 14313

**BALL VALVES "3 PIECE" FULL BORE
ROBINETS A BOISSEAU SPHERIQUE
"3 PIECES" PASSAGE INTEGRAL
KUGELHÄHNE "3 TEILIG"
VOLLER DURCHGANG**

WEB SITE: WWW.ADLERSPA.COM

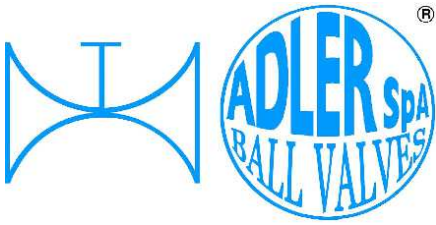

ISO 9001 by L.R.
 PED DIR. 2014/68/UE by L.R.
 ATEX DIR. 2014/34/UE by B.V.
 FIRE SAFE EXECUTION BS6755/API 607 by L.R.
 FIRE SAFE TESTED ISO 10497 by L.R.
 ISO 15848 by TÜV
 ANTISTATIC DEVICE by L.R.
 EAC CERTIFICATION by B.V.

TYPE
FP3
 PN 20 ÷ 100

VALVOLA A SFERA "3 PEZZI" PASSAGGIO TOTALE
BALL VALVES "3 PIECE" FULL BORE
ROBINETS A BOISSEAU SPHERIQUE "3 PIECES" PASSAGE INTEGRAL
KUGELHÄHNLE "3 TEILIG" VOLLER DURCHGANG

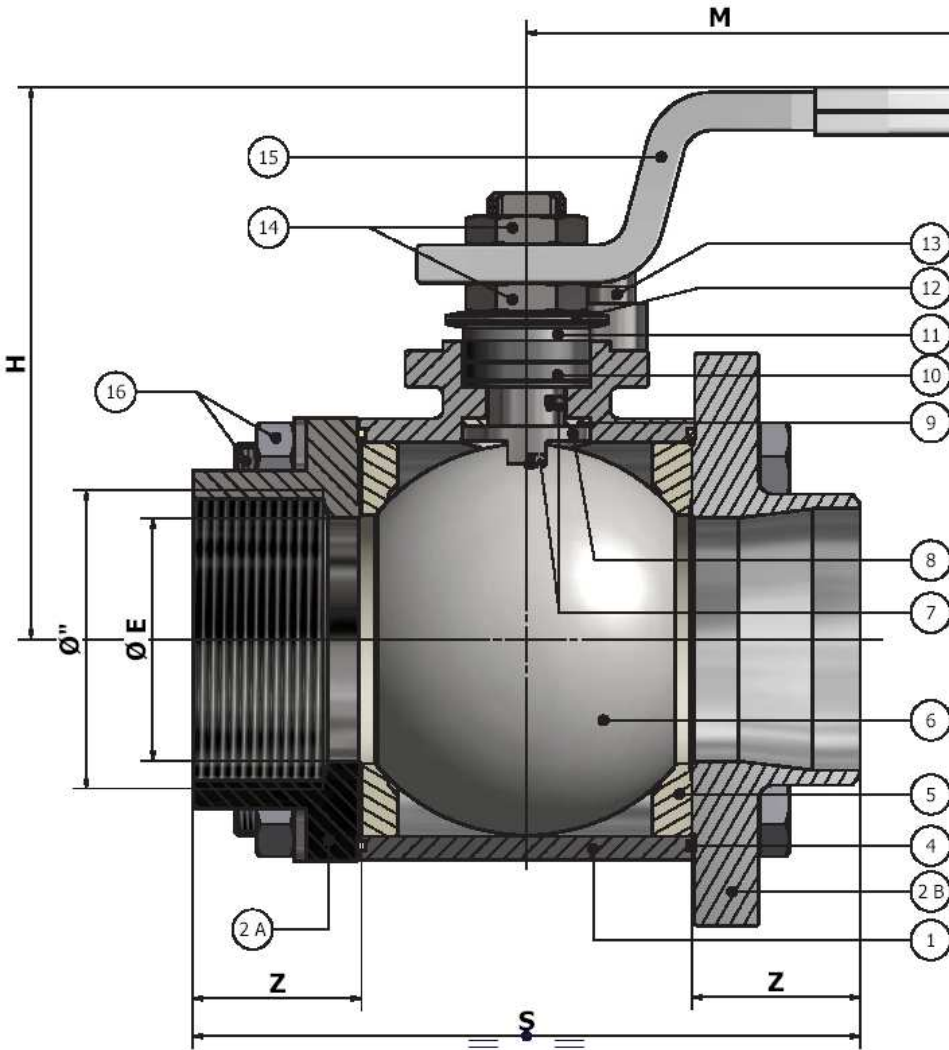

CONNECTIONS:
 EN 10226-1 (EX ISO 7-1 Rp)
 ANSI B1.20.1 NPT
 S.W.
 B.W.

VISUALIZZA 3D
SEE 3D

<https://adlerspa.com/prodotti/fp3>

REF. 16
 N° 4
 From ND 1/4" to ND 22
 N° 6
 From ND 2 1/2" to ND 4"

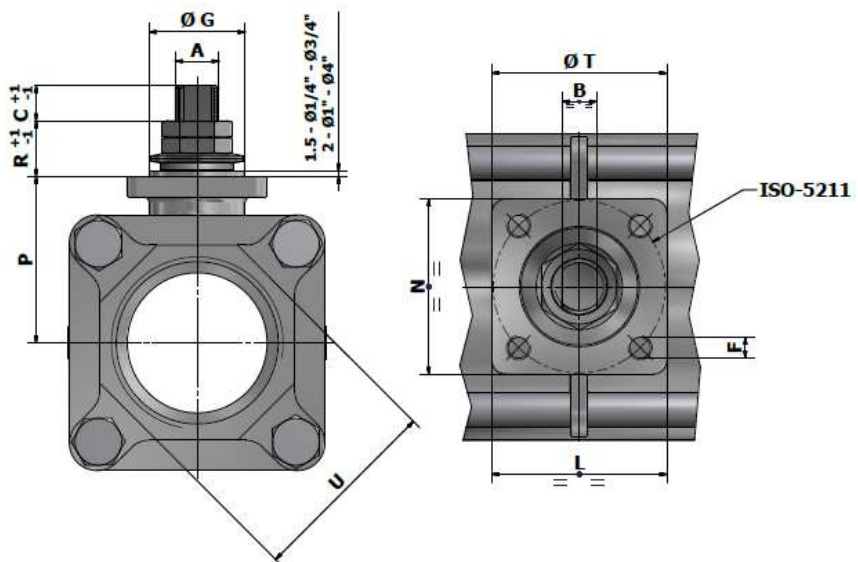

FOR CONNECTION SHAPE OF C.S. VALVES
 SEE EXECUTION 17

FOR CONNECTION SHAPE OF S.S. VALVES
 SEE EXECUTION 18

(FOR DIMENSIONS SEE TABLES ON
 PAG. 3 AND FOR B.W. - S.W. ENDS SEE
 PAG. 6)

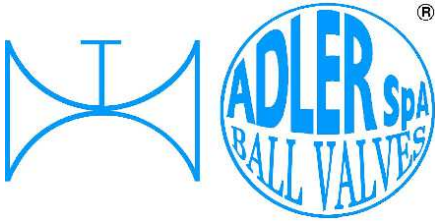

ISO 9001 by L.R.
 PED DIR. 2014/68/UE by L.R.
 ATEX DIR. 2014/34/UE by B.V.
 FIRE SAFE EXECUTION BS6755/API 607 by L.R.
 FIRE SAFE TESTED ISO 10497 by L.R.
 ISO 15848 by TÜV
 ANTISTATIC DEVICE by L.R.
 EAC CERTIFICATION by B.V.

TYPE
FP3
 PN 20 ÷ 100

N.	DESCRIZIONE DESCRIPTION DESCRIPTION BESCHREIBUNG	MATERIALI MATERIALS MATERIAUX WERKSTOFFE
1	CORPO BODY CORPS MITTE	ASTM A 351 CF8M
2	LATERALE END LATERAL ENDE	ASTM A105 (2B G7/NPT) galvanized ASTM A105 (2B BW/SW) burnished ASTM A 351 CF8M (2A G7/NPT) ASTM A 351 CF3M (2A BW/SW)
3		
4*	ANELLO SEAL ANNEAU DICHTUNGSRING	P.T.F.E.
5*	SEDE SEAT SIEGE SITZRING	P.T.F.E. R.P.T.F.E. (OPTIONAL)
6	SFERA BALL BOULE KUGEL	ASTM A479 304/304L ASTM A351 CF8 ASTM A479 316/316L ASTM A351 CF8M
7	DISPOSITIVO ANTISTATICO ANTISTATIC DEVICE CONTACT ANTISTATIQUE ANTISTATIK VORRICHTUNG	ASTM A479 316/316L
8	STELO STEM TIGE SPINDEL	ASTM A479 304/304L ASTM A479 316/316L

N.	DESCRIZIONE DESCRIPTION DESCRIPTION BESCHREIBUNG	MATERIALI MATERIALS MATERIAUX WERKSTOFFE
9*	BUSSOLA STEM SEAL JOINT TIGE UNTERE SPINDELABDICHTUNG	P.T.F.E.
10*	PACCO A "V" CHEVRON RINGS JOINT A "V" 3 FACHE DACHMANSCHETTE	P.T.F.E. / GRAFITE P.T.F.E. / GRAPHITE P.T.F.E. / GRAPHITE P.T.F.E. / GRAPHIT
11	PREMIBUSSOLA PRESSING BUSH PRESSE RONDELLE STOPFBUCHSDRUCKRING	ASTM A479 304
12	MOLLE A TAZZA SPRING WASHERS RONDELLES BELLEVILLE TELLERFEDERN	C72/50Cr V ₄ X10CrNi18.8 ZINCATO - GALVANIZED - ZINGUE - VERZINKT ON REQUEST
13	VITE DI FERMO E FERMO PIN AND STOP PIN PLOT ET PLOT D'ARRET ANSCHLAGBOLZEN	UNI3740 8.8 UNI 3951 A2-70 ZINCATO - GALVANIZED - ZINGUE - VERZINKT ON REQUEST
14	DADO - CONTRODADO NUT - LOCK NUT ECROU - CONTRE-ECROU MUTTER - KONTERMUTTER	UNI 3740 - 6S ASTM A479 304 ZINCATO - GALVANIZED ZINGUE - VERZINKT ON REQUEST
15	LEVA WRENCH LEVIER HANDHEBEL	AISI 1010 ASTM A479 304 GALVANIZED AND PAINTED FOR S.S VALVES PAINTED FOR C.S. VALVES ON REQUEST
16	BULLONE BOLT BOULON GEWINDEBOLZEN	UNI 3740 8.8 UNI 3951 A2-70 ZINCATO - GALVANIZED - ZINGUE - VERZINKT ON REQUEST

* RICAMBI CONSIGLIATI - RECOMMENDED SPARE PARTS - PIECES DE RECHANGE CONSEILLEES - ERSATZTEIL EMPFEHLUNG
 ON REQUEST P.T.F.E. AVAILABLE CERTIFIED BAM, FDA, MOCA

DIMENSIONI - DIMENSION - DIMENSIONS - ABMESSUNGEN

Ø	1/4"	3/8"	1/2"	3/4"	1"	1 1/4"	1 1/2"	2"	2 1/2"	3"	4"			
AxB	8x5	8x5	10x6	10x6	12x8	12x8	16x10	16x10	22x14	22x14	30x18			
C	6	6	7	7	10	10	15	15	17	17	17			
D	34,6	34,6	43,1	49,2	60,8	67,9	84	101,8	123	143	176			
E	10	10	15	19	25	30	38	51	64	76	101			
F	M5	M5	M5	M5	M5	M5	M6	M6	M8	M8	M8			
ISO	F03	F03	F03	F03	F03	F03	F05	F05	F07	F07	F07			
G	25	25	25	25	25	25	35	35	55	55	55			
H	46	46	66	68	85	91	106	116	140	148	174			
L=N	33	33	36	36	36	36	51	51	65	65	70			
M	120	120	145	145	185	185	280	280	370	370	470			
P	22,2	22,2	32,5	35	41	45,5	53	60,5	77,5	86	99,5			
R	7	7	8	8	17	17	20	20	23	23	26			
S	50	60	75	80	90	110	120	140	185	205	240			
T	36	36	36	36	36	36	50	50	70	70	70			
U		22	26	32	38	47	54	66				ONLY FOR MICROCASTED ENDS G7, NPT AND S.W.		
Z	15,1	20,1	24,5	25,7	26,5	32,7	33,2	34,75	51	54	61			
Bolts M	5x40	5x40	6x55	6x55	8x70	8x80	10x90	10x110	12x120	14x140	14x170			
PN	100	100	63	63	40	40	40	40	25	25	20			
Kg	0,3	0,35	0,75	0,85	1,35	1,75	3,3	4,9	8	15	23,5	ENDS FROM BAR STOCK		
Kg												ENDS FROM CAST		

- DATI E CARATTERISTICHE SOGGETTI A VARIAZIONI SENZA PREAVVISO
- SPECIFICATIONS SUBJECT TO MODIFICATION WITHOUT PRIOR NOTICE
- TOUS DROITS DE MODIFICATION RESERVES
- KONSTRUKTIONÄNDERUNGEN VORBEHALTEN



ADLER SpA - BALL VALVES
 20010 S. STEFANO TICINO (MI) ITALY V.le BORLETTI, 14 Tel. +39/02974842.11 FAX +39/0297271698
 E-mail: adler@adlerspa.com <http://www.adlerspa.com>

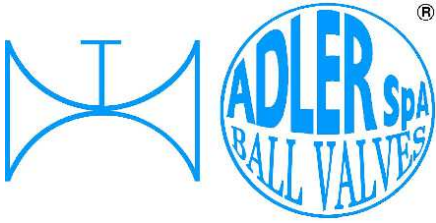

ISO 9001 by L.R.
 PED DIR. 2014/68/UE by L.R.
 ATEX DIR. 2014/34/UE by B.V.
 FIRE SAFE EXECUTION BS6755/API 607 by L.R.
 FIRE SAFE TESTED ISO 10497 by L.R.
 ISO 15848 by TÜV
 ANTISTATIC DEVICE by L.R.
 EAC CERTIFICATION by B.V.

TYPE
FP3
 PN 20 ÷ 100

▪ ESECUZIONI ▪ EXECUTIONS ▪ EXECUTIONS ▪ AUSFÜHRUNGEN



EXECUTION 4 - 12



EXECUTION 6 - 16

S STANDARD

O OPTIONAL

1 **S**

CYLINDRICAL THREAD

EN 10226-1 (ex ISO 7-1 Rp)

S

ONLY FOR VALVES ≥ DN 50

FORO DI BILANCIAMENTO
 BALANCING HOLE
 TROU DE BALANCEMENT
 DRUCKENTLASTUNGSBOHRUNG

ON REQUEST AVAILABLE ON DN ≤ 40

3 **S**

-TIRANTI GUIDATI - GUIDED BOLTS
 -BOULONS GUIDES -ZUGBOLZEN GEFÜHRT

4 **S**

-STELO ANTI ESPULSIONE -ANTI BLOW OUT STEM
 -TIGE ANTIEXPULSION -AUSBLASGESICHERETE WELLE

-PACCO A "V" -CHEVRON RINGS
 -JOINT A "V" -3 FACHE DACHMANSCHETE
 ANTISTATIC DEVICE ANTISTATIK VORRICHTUNG
 BS 5146

5 **O**

DN 10 ÷ 32

103 (DN 10 - 20)
 145 (DN 25 - 32)

69 (DN 10 - 20)
 79 (DN 25 - 32)

57

-MANIGLIA OVALE - OVAL HANDLE
 -LEVIER OVAL -HANDHEBEL IN OVALFORM

6 **O**

BREVETTO - PATENTED
 00219688 - 21-04-1993

FKM (VITON)

From Ø 1/2" to 4"

-“O” RING STELO “O” RING ON STEM
 -TIGE AVEC “O” RING
 -“O” RING IM SPINDELBEREICH

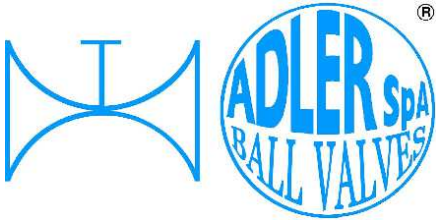

ISO 9001 by L.R.
 PED DIR. 2014/68/UE by L.R.
 ATEX DIR. 2014/34/UE by B.V.
 FIRE SAFE EXECUTION BS6755/API 607 by L.R.
 FIRE SAFE TESTED ISO 10497 by L.R.
 ISO 15848 by TÜV
 ANTISTATIC DEVICE by L.R.
 EAC CERTIFICATION by B.V.

TYPE
FP3
 PN 20 ÷ 100

7 **O**

-PROLUNGA STELO -STEM EXTENSION
 -TIGE PROLONGEE -SPINDELVERLÄNGERUNG

8 **O**

-PARTICOLARI INOX
 -STAINLESS STEEL DETAILS
 -ACCESSOIRES EN INOX
 -EDELSTAHLTEILE

9 **S**

-ATTACCO "ISO" -"ISO" CONNECTIONS
 -SYSTEM "ISO" -ANSCHLUSS "ISO"

10 **O**

STOCK BAR EXECUTION

11 **O**

-TENUTA INTEGRALE -POCKETLESS SEATS
 -TENUE INTEGRALE -TOTRAUMARM

12 **O**

FIRE SAFE ISO 10497 "ISO-FT" (BS 6755 / API 607)

13 **S**

-ANELLO CONTENUTO -ANNEAU CONTENU
 -CONTAINED SEAL -DICHRING GEKAMMERT

14 **O**

VEDERE / SEE ANSI B16.34

FLUSSO FLOW

-FORO DI SCARICO NELLA SFERA -OVERPRESSURE HOLE INTO BALL
 -TROU DECOMPRESSION DANS LA BOULE
 -ENTLASTUNGSBOHRUNG IN DER KUGEL
 VALVOLA MONO DIREZIONALE
 MONO-DIRECTIONAL VALVE

15 **O**

P.T.F.E./GRAPHITE
 P.T.F.E.
 100-250

- SERVIZIO CRIOGENICO - CRYOGENIC SERVICE
 - SERVICE CRYOGENIQUE
 - TIEFTEMPERATUR SERVICE

16 **O**

-FIRE SAFE ISO FT+ "O" RING STELO
 -FIRE SAFE ISO FT+ "O" RING ON STEM
 -SECURITE FEU ISO FT+ TIGE AVEC "O" RING
 -FEUERSICHERE AUSFÜHRUNG ISO FT+ "O" RING IM SPINDELBEREICH

17 **S**

LATERALI DA BARRA ENDS FROM BAR STOCK
 (ASTM A 105)
 G7 Rp / NPT galvanized
 BW / SW burnished

CONNECTION SHAPE

18 **S**

LATERALI MICROFUSI MICROCAST ENDS
 (ASTM A351 CF8M TYPE G7 Rp and NPT)
 (ASTM A351 CF3M TYPE BW and SW)

03/8" - 2" G7-NPT-SW
 01/4" / 02 1/2" - 4" G7-NPT-SW
 01/4"-4" BW

CONNECTION SHAPE

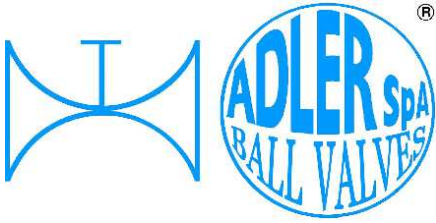

ISO 9001 by L.R.
 PED DIR. 2014/68/UE by L.R.
 ATEX DIR. 2014/34/UE by B.V.
 FIRE SAFE EXECUTION BS6755/API 607 by L.R.
 FIRE SAFE TESTED ISO 10497 by L.R.
 ISO 15848 by TÜV
 ANTISTATIC DEVICE by L.R.
 EAC CERTIFICATION by B.V.

TYPE
FP3
 PN 20 ÷ 100

DIMENSIONI LATERALI - ENDS DIMENSION - DIMENSIONS LATERAL - ABMESSUNGEN GEHÄUSEFLANSCH

**BUTT WELDING
 UNI EN 12627**

(Standard ADLER – EX DIN 3239)

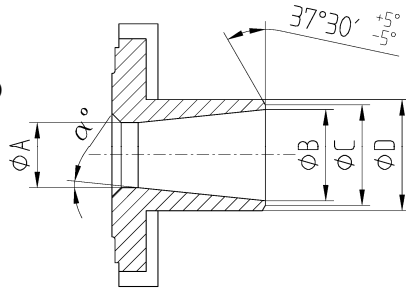

\emptyset	1/4"	3/8"	1/2"	3/4"	1"	1 1/4"	1 1/2"	2"	2 1/2"	3"	4"
$\emptyset A$	10	10	15	19	25	30	38	51	64	76	101
$\emptyset B$	10	13	17	22	28	36.2	43	54	70	82	106
$\emptyset C$	12	15	19	24	30	38.2	45	56	72	84	108
$\emptyset D$	14	18	22	28	34	42.2	49	61	77	90	115
α°	0	5°	3°	4°	4°	7°	5°	3°	4°	5°	3°

**BUTT WELDING
 ANSI B 16.25**

(OPTIONAL)

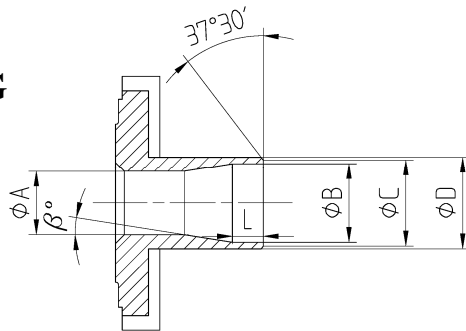

\emptyset	1/4"	3/8"	1/2"	3/4"	1"	1 1/4"	1 1/2"	2"	2 1/2"	3"	4"
$\emptyset A$	10	10	15	19	25	30	38	51	64	76	101
$\emptyset B$	10	12,5	15,8	21	26,7	35,1	40,9	52,5	62,7	77,9	102,3
$\emptyset C$	11,6	14,1	17,4	22,6	28,3	36,7	42,5	54,5	64,7	79,9	104,3
$\emptyset D$	14	17,5	22	27,5	34,5	43,5	50	62	73	90	114,3
L		3,5	4,2	4,3	5,1	5,4	5,6	5,9	7,8	-	9,1
β°		5°	5°	4°	3°	7°	4°	2°	2°	2°	2°

**SOCKET WELDING
 ADLER STANDARD**

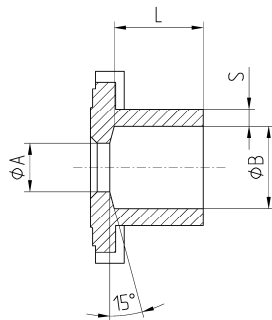

\emptyset	1/4"	3/8"	1/2"	3/4"	1"	1 1/4"	1 1/2"	2"	2 1/2"	3"	4"
$\emptyset A$	10	10	15	19	25	30	38	51	64	76	101
$\emptyset B$	13,8	17,7	21,8	27,4	34,2	42,8	48,9	61	76,6	89,6	115,2
L	10	16,5	21	21	21	26	26,5	27,3	42,5	46	51
L*	10	10	10	13	13	13	13	16	16	16	20
S	2,1	2,15	2,1	2,3	1,8	2,1	2,55	2,5	2,7	2,95	3,4

* Dimensione per Laterale da barra / Dimension for End by bar