



ISO 9001:2015 by L.R.
PED DIR. 2014/68/UE by L.R.
ATEX DIR. 2014/34/UE by B.V.
FIRE SAFE EXECUTION by L.R.
ISO 15848 by TÜV
ANTISTATIC DEVICE by L.R.
FIRE SAFE TESTED ISO 10497 by L.R.
EAC CERTIFICATION by B.V.

TYPE
FT4
PN 10 ÷ 40
ANSI 150 ÷ 300

NORME E DIRETTIVE APPLICATE DISPONIBILI AL SEGUENTE LINK:
STANDARD AND DIRECTIVE APPLIED AVAILABLE AT FOLLOWING LINK:
http://www.adlerspa.com/pdf/NORME_ADLER.pdf

VALVOLE A SFERA "3 VIE CORPO PIATTO" PASSAGGIO TOTALE 90° CON CAMICIA DI RISCALDAMENTO

FULL BORE ACCORDING
TO ISO 14313



On request S.S. certified
MOCA
According to
1935/2004/EU

On request
S.I.L. 3
According to IEC 61508

On request
FIRE SAFE
According to ISO 10497
"ISO-FT"

CONSTRUCTION ACCORDING TO:
ANSI B16.34 - BS EN 12516-2

**BALL VALVES "3 WAY WAFER" FULL BORE 90°
WITH HEATING JACKET**

**ROBINETS A BOISSEAU SPHERIQUE
"3 VOIES WAFER" PASSAGE INTEGRAL 90° AVEC
ENVELOPPE**

**KUGELHÄHNE "3 WEGE KOMPAKTHAHN"
VOLLER DURCHGANG 90° MIT HEIZMANTEL**

WEB SITE: WWW.ADLERSPA.COM

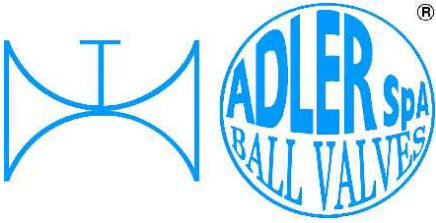

ISO 9001:2015 by L.R.
 PED DIR. 2014/68/UE by L.R.
 ATEX DIR. 2014/34/UE by B.V.
 FIRE SAFE EXECUTION by L.R.
 ISO 15848 by TÜV
 ANTISTATIC DEVICE by L.R.
 FIRE SAFE TESTED ISO 10497 by L.R.
 EAC CERTIFICATION by B.V.

TYPE
FT4
 PN 10 ÷ 40
 ANSI 150 ÷ 300

VALVOLA A SFERA "3 VIE CORPO PIATTO" PASSAGGIO TOTALE 90° CON CAMICIA DI RISCALDAMENTO
 BALL VALVES "3 WAY WAFER" FULL BORE 90° WITH HEATING JACKET
 ROBINETS A BOISSEAU SPHERIQUE "3 VOIES WAFER" PASSAGE INTEGRAL 90° AVEC ENVELOPPE
 KUGELHÄHNE "3 WEGE KOMPAKTHAHN" VOLLER DURCHGANG 90° MIT HEIZMANTEL

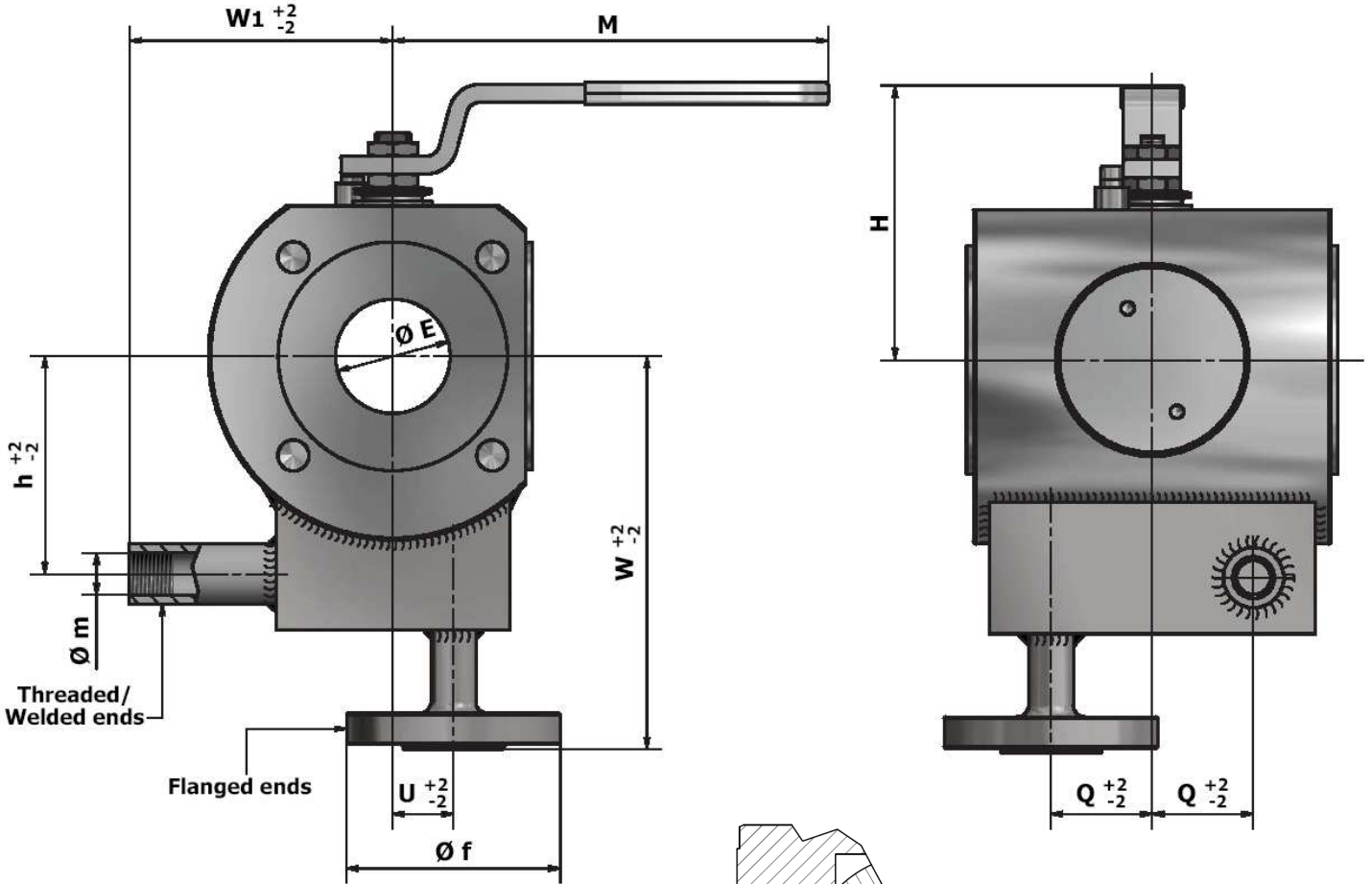

Scartamento – Face to face: S1

Valvola base FT4
 Main Ball Valve FT4

Pressione massima di lavoro nelle camicie 10 bar
 Maximum working pressure for jacket 10 bar

Materiale camicia Jacket material	CARBON STEEL (STANDARD) STAINLESS STEEL (OPTIONAL)
--------------------------------------	---

Per montaggio con guarnizioni
 spirrometalliche, contattare Adler Spa.
 For assembling with spiral-wound
 gaskets, contact Adler Spa

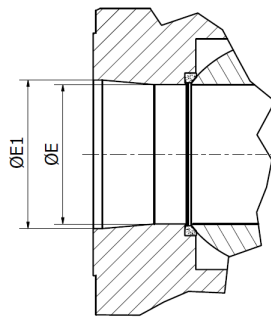

DN 100 ÷ 150

DN 65 PN 16 ESECUZIONE
 STANDARD CON 4 FORI
 SU RICHIESTA DISPONIBILE
 CON 8 FORI
 DN 65 PN 16 STANDARD
 EXECUTION WITH 4 HOLES
 ON REQUEST AVAILABLE WITH
 8 HOLES

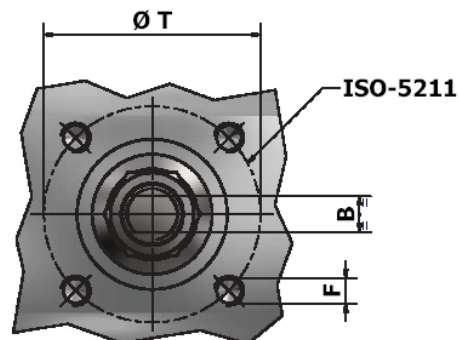

POSIZIONI OTTENIBILI
 OBTAINABLE POSITIONS
 POSITIONS OBTENABLES
 MÖGLICHE STELLUNGEN

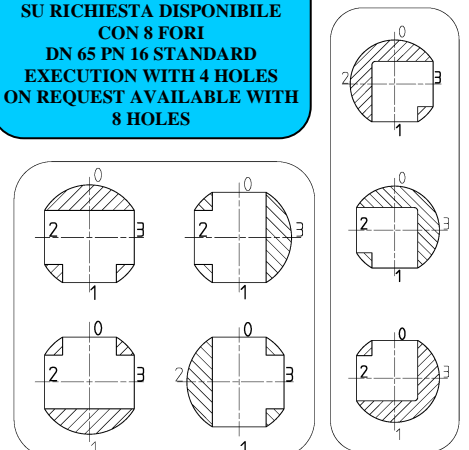



ISO 9001:2015 by L.R.
 PED DIR. 2014/68/UE by L.R.
 ATEX DIR. 2014/34/UE by B.V.
 FIRE SAFE EXECUTION by L.R.
 ISO 15848 by TÜV
 ANTISTATIC DEVICE by L.R.
 FIRE SAFE TESTED ISO 10497 by L.R.
 EAC CERTIFICATION by B.V.

TYPE
FT4
 PN 10 ÷ 40
 ANSI 150 ÷ 300

N.	DESCRIZIONE DESCRIPTION DESCRIPTION BESCHREIBUNG	MATERIALI MATERIALS MATERIAUX WERKSTOFFE
1	CORPO BODY CORPS MITTE	ASTM A105 ASTM A479 304/304L ASTM A479 316/316L
2	GHIERA INSERT EMBOUT GEWINDEDRUCKRING	ASTM A105 ASTM A479 304/304L ASTM A479 316/316L
3*◇	O-RING	FKM (VITON)
4*	ANELLO SEAL ANNEAU DICHTUNGSRING	P.T.F.E.
5*	SEDE SEAT SIEGE SITZRING	P.T.F.E. R.P.T.F.E. (OPTIONAL)
6	SFERA BALL BOULE KUGEL	ASTM A479 304/304L ASTM A351 CF8 ASTM A479 316/316L ASTM A351 CF8M
7	DISPOSITIVO ANTISTATICO ANTISTATIC DEVICE CONTACT ANTISTATIQUE ANTISTATIK VORRICHTUNG	ASTM A479 316/316L
8	STELO STEM TIGE SPINDEL	ASTM A479 304/304L ASTM A479 316/316L
9*	BUSSOLA STEM SEAL JOINT TIGE UNTERE SPINDELABDICHTUNG	P.T.F.E.
10*	PACCO A "V" CHEVRON RINGS JOINT A "V" 3 FACHE DACHMANSCHETTE	P.T.F.E. / GRAFITE P.T.F.E. / GRAPHITE P.T.F.E. / GRAPHITE P.T.F.E. / GRAPHIT

N.	DESCRIZIONE DESCRIPTION DESCRIPTION BESCHREIBUNG	MATERIALI MATERIALS MATERIAUX WERKSTOFFE
11	PREMIBUSSOLA PRESSING BUSH PRESSE RONDELLE STOPFBÜCHSDRUCKRING	ASTM A479 304
12	MOLLE A TAZZA SPRING WASHERS RONDELLES BELLEVILLE TELLERFEDERN	C72/50Cr V4 X10CrNi18.8 ZINCATO - GALVANIZED - ZINGUE - VERZINKT ON REQUEST
13	VITE DI FERMO E FERMO PIN AND STOP PIN PLOT ET PLOT D'ARRET ANSCHLAGBOLZEN	UNI3740 8.8 UNI 3951 A2-70 ZINCATO - GALVANIZED - ZINGUE - VERZINKT ON REQUEST
14	DADO - CONTRODADO NUT - LOCK NUT ECROU - CONTRE-ECROU MUTTER - KONTERMUTTER	UNI 3740 - 6S ASTM A479 304 ZINCATO - GALVANIZED ZINGUE - VERZINKT ON REQUEST
15	LEVA WRENCH LEVIER HANDHEBEL	AISI 1010 ASTM A479 304 CHROMED FOR S.S. VALVES PAINTED FOR C.S. VALVES ON REQUEST
21	GHIERA INSERT EMBOUT GEWINDEDRUCKRING	ASTM A105 ASTM A479 304/304L ASTM A479 316/316L
22*	ANELLO SEAL ANNEAU DICHTUNGSRING	P.T.F.E.
23*	O-RING	FKM (VITON)
24	GHIERA INSERT EMBOUT GEWINDEDRUCKRING	ASTM A105 ASTM A479 304/304L ASTM A479 316/316L

* RICAMBI CONSIGLIATI - RECOMMENDED SPARE PARTS - PIECES DE RECHANGE CONSEILLEES - ERSATZTEIL EMPFEHLUNG

◇ WAY 0 : IN VALVES FROM DN65 TO DN150 / WAY 1 : IN ALL VALVES / WAY 3 : ONLY IN VALVES DN20, 25, 32, 40, 80, 100, 125,150

DIMENSIONI - DIMENSION - DIMENSIONS - ABMESSUNGEN

DN	10	15	20	25	32	40	50	65	65	80	100	100	
C		7	7	10	10	15	15	17		17	17		
ØE		15	19	25	30	38	51	64		69	87		
ØE1		-	-	-	-	-	-	-		76	101		
F		M5	M5	M5	M5	M6	M6	M8		M8	M10		
f		DN 15 PN 16						DN 25 PN 16					
ISO		F03	F03	F03	F03	F05	F05	F07		F07	F10		
H		70	75	90	95	112	122	147		149	174		
h		61	70	72	85	85	97	105		131	150		
M		145	145	185	185	280	280	370		370	470		
m		Ø1/2" GAS						Ø1" GAS					
P		36,6	41	46	51	57	67	85		87	99,5		
Q		20	25	28	35	35	45	50		70	70		
R		8	8	17	17	20	20	23		23	26		
S		32	40	41,5	52,5	56,5	62	70		87	96		
S1		97	108	115	140	150	165	185		216	230		
T		36	36	36	36	50	50	70		70	102		
U		0	10	10	19	20	25	30		50	55		
W		135	145	150	160	165	175	185		210	235		
W1		95	95	95	115	120	125	1310		150	165		
-Kg		5	7,5	8,5	13,5	17	19,5	27		56	71		

- DATI E CARATTERISTICHE SOGGETTI A VARIAZIONI SENZA PREAVVISO
- SPECIFICATIONS SUBJECT TO MODIFICATIONS WITHOUT PRIOR NOTICE
- TOUS DROITS DE MODIFICATION RESERVES
- KONSTRUKTIONÄNDERUNGEN VORBEHALTEN

PN 10 ÷ 16 - ANSI 150

PN 25 ÷ 40 on request

PN 10 ÷ 40

DN 100 ANSI 150 S=100,5 S₁= 240



ADLER SpA - BALL VALVES
 20010 S. STEFANO TICINO (MI) ITALY V.le BORLETTI, 14 Tel. +39/02974842.11 FAX +39/0297271698
 E-mail: adler@adlerspa.com <http://www.adlerspa.com>

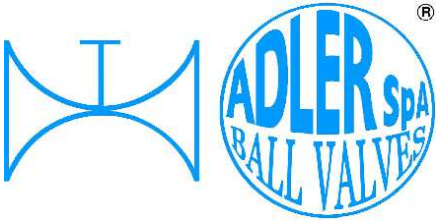

ISO 9001:2015 by L.R.
 PED DIR. 2014/68/UE by L.R.
 ATEX DIR. 2014/34/UE by B.V.
 FIRE SAFE EXECUTION by L.R.
 ISO 15848 by TÜV
 ANTISTATIC DEVICE by L.R.
 FIRE SAFE TESTED ISO 10497 by L.R.
 EAC CERTIFICATION by B.V.

TYPE
FT4
 PN 10 ÷ 40
 ANSI 150 ÷ 300

• ESECUZIONI • EXECUTIONS • EXECUTIONS • AUSFÜHRUNGEN



EXECUTION 4- 12

ONLY FOR VALVES \geq DN 50 **S**

FORO DI BILANCIAMENTO
 BALANCING HOLE
 TROU DE BALANCEMENT
 DRUCKENTLASTUNGSBOHRUNG

ON REQUEST AVAILABLE ON DN \leq 40



EXECUTION 6 - 16

S STANDARD

O OPTIONAL

1 **S**

-MONTAGGIO VITI – SCREW ASSEMBLING
 -MONTAGE VIS – EINBAU MIT SCHRAUBEN

2 **S**

INDICATORE DI FLUSSO
 FLOW INDICATOR

ADLER

UNA GAMMA COMPLETA
 PRIVILEGIANDO LA QUALITA'

A COMPLETE RANGE PRIVILEGING
 THE QUALITY

4 **S**

-STELO ANTI ESPULSIONE –ANTI BLOW OUT STEM
 -TIGE ANTIEXPULSION –AUSBLASGESICHERTE WELLE

-PACCO A "V" –CHEVRON RINGS
 -JOINT A "V" –3 FACHE DACHMANSCHETE
 ANTISTATIC DEVICE ANTISTATIK VORRICHTUNG
 BS 5146

ANTISTATIC DEVICE
 CERTIFICATE

6 **O**

BREVETTO – PATENTED
 00219688

-“O” RING STELO “O” RING ON STEM
 -TIGE AVEC “O” RING
 -“O” RING IM SPINDELBEREICH

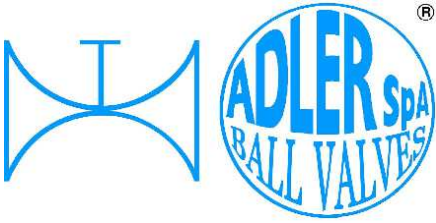

ISO 9001:2015 by L.R.
 PED DIR. 2014/68/UE by L.R.
 ATEX DIR. 2014/34/UE by B.V.
 FIRE SAFE EXECUTION by L.R.
 ISO 15848 by TÜV
 ANTISTATIC DEVICE by L.R.
 FIRE SAFE TESTED ISO 10497 by L.R.
 EAC CERTIFICATION by B.V.

TYPE
FT4
 PN 10 ÷ 40
 ANSI 150 ÷ 300

7

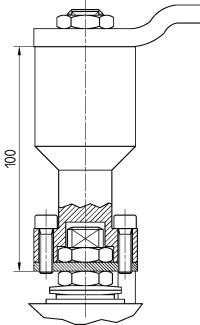

-PROLUNGA STELO -STEM EXTENSION
 -TIGE PROLONGEE -SPINDELVERLÄNGERUNG

8

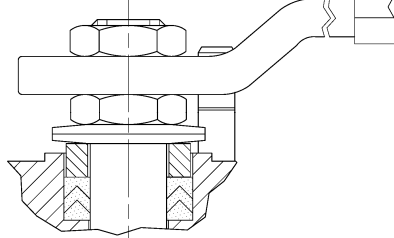

-PARTICOLARI INOX
 -STAINLESS STEEL DETAILS
 -ACCESSOIRES EN INOX
 -EDELSTAHLTEILE

9

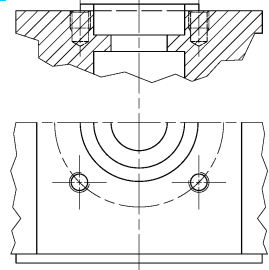

-ATTACCO "ISO" -"ISO" CONNECTIONS
 -SYSTEM "ISO" -ANSCHLUSS "ISO"

10

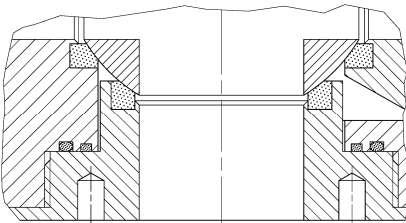

-SFERA CONTENUTA -CONTENTS BALL
 -BOULE CONTENUE
 -NICHT RAUSRAGENDE KUGEL

AQUILA - AEGLE - AIGLE
 ADLER



12

FIRE SAFE
 ISO 10497 "ISO-FT"
 (BS 6755 / API 607)



13

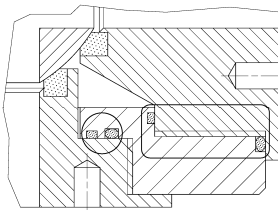

-DOPPIA TENUTA -DOUBLE SEALS
 -DOUBLE ETANCHEITE -DOPPELTE ABDICHTUNG
 -GHIERA A BATTUTA -METAL BEATING RING
 -EMBOUT AVEC BATTUE MECANIQUE
 -METALLISCHER ANSCHLAG DES
 GEWINDEDRUCKRINGS

14

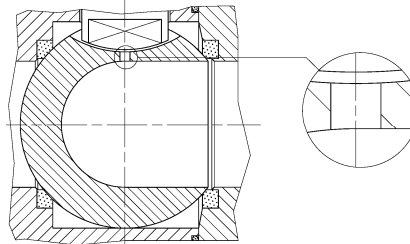

-FORO DI SCARICO NELLA SFERA
 -OVERPRESSURE HOLE INTO BALL
 -TROU DECOMPRESSION DANS LA BOULE
 -ENTLASTUNGSBOHRUNG IN DER KUGEL

DIMENSION CHECK



16



-FIRE SAFE ISO FT+ "O" RING STELO
 -FIRE SAFE ISO FT+ "O" RING ON STEM
 -SECURITE FEU ISO FT+ TIGE AVEC "O" RING
 -FEUERSICHERE AUSFÜHRUNG ISO FT+
 "O" RING IM SPINDELBEREICH

17

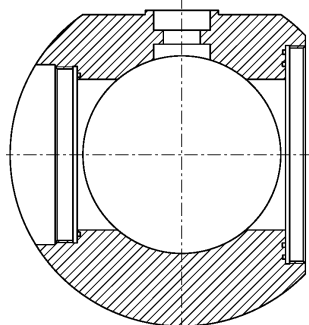

ADLER

UNA GAMMA COMPLETA
 PRIVILEGIANDO LA QUALITA'
 A COMPLETE RANGE PRIVILEGING
 THE QUALITY



ISO 9001:2015 by L.R.
 PED DIR. 2014/68/UE by L.R.
 ATEX DIR. 2014/34/UE by B.V.
 FIRE SAFE EXECUTION by L.R.
 ISO 15848 by TÜV
 ANTISTATIC DEVICE by L.R.
 FIRE SAFE TESTED ISO 10497 by L.R.
 EAC CERTIFICATION by B.V.

TYPE
FT4
 PN 10 ÷ 40
 ANSI 150 ÷ 300

VITI D'ASSEMBLAGGIO PER FT4 - ASSEMBLING SCREWS FOR FT4 - VIS D'ASSEMBLAGE POUR FT4- MONTAGESCHRAUBEN FÜR FT4
 N° VITI - DIMENSIONE • N° SCREW - DIMENSIONS • N° VIS- DIMENSIONS • N° SCHRAUBEN - ABMESSUNGEN

EUROPEAN NORM

DN PN	15		20		25		32		40		50		65		80		100		125		150		200	
16	12	M12 X30	12	M12 X30	12	M12 X30	12	M16 X35	12	M16 X35	12	M16 X40	12	M16 X40	24	M16 X40	24	M16 X40						
25	12	M12 X30	12	M12 X35	12	M12 X35	12	M16 X40	12	M16 X40	12	M16 X40	24	M16 X45	24	M16 X45	24	M20 X50						
40	12	M12 X30	12	M12 X35	12	M12 X35	12	M16 X40	12	M16 X40	12	M16 X40	24	M16 X45	24	M16 X45	24	M20 X50						

* N° 8 per UNI 2223/2229

ANSI METRIC

(STANDARD ADLER)

Ø Rating	1/2"		3/4"		1"		1 1/4"		1 1/2"		2"		2 1/2"		3"		4"		5"		6"		8"	
150	12	M14 X30	12	M14 X30	12	M14 X30	12	M14 X35	12	M14 X35	12	M16 X40	12	M16 X40	12	M16 X45	24	M16 X45						

ANSI B1.1 UNC

(ON REQUEST)

Ø Rating	1/2"		3/4"		1"		1 1/4"		1 1/2"		2"		2 1/2"		3"		4"		5"		6"		8"	
150	12	1/2 X 1 1/4	12	1/2 X 1 1/4	12	1/2 X 1 1/4	12	1/2 X 1 1/4	12	1/2 X 1 1/2	12	5/8 X 1 1/2	12	5/8 X 1 3/4	12	5/8 X 1 3/4	24	5/8 X 1 3/4						

Length of screws calculated considering a gasket with thickness of 2,5 mm.

