

ISO 9001 by L.R.
PED DIR. 2014/68/UE by L.R.
ATEX DIR. 2014/34/UE by B.V.
FIRE SAFE EXECUTION BS6755/API 607 by L.R.
FIRE SAFE TESTED ISO 10497 by L.R.
ISO 15848 by TÜV
ANTISTATIC DEVICE by L.R.
EAC CERTIFICATION by B.V.

TYPE
FX1
PN 10 ÷ 40
ANSI 150 ÷ 300

NORME E DIRETTIVE APPLICATE DISPONIBILI AL SEGUENTE LINK:
STANDARD AND DIRECTIVE APPLIED AVAILABLE AT FOLLOWING LINK:
http://www.adlerspa.com/pdf/NORME_ADLER.pdf

VALVOLE A SFERA "CORPO PIATTO" PASSAGGIO TOTALE CON CAMICIA DI RISCALDAMENTO

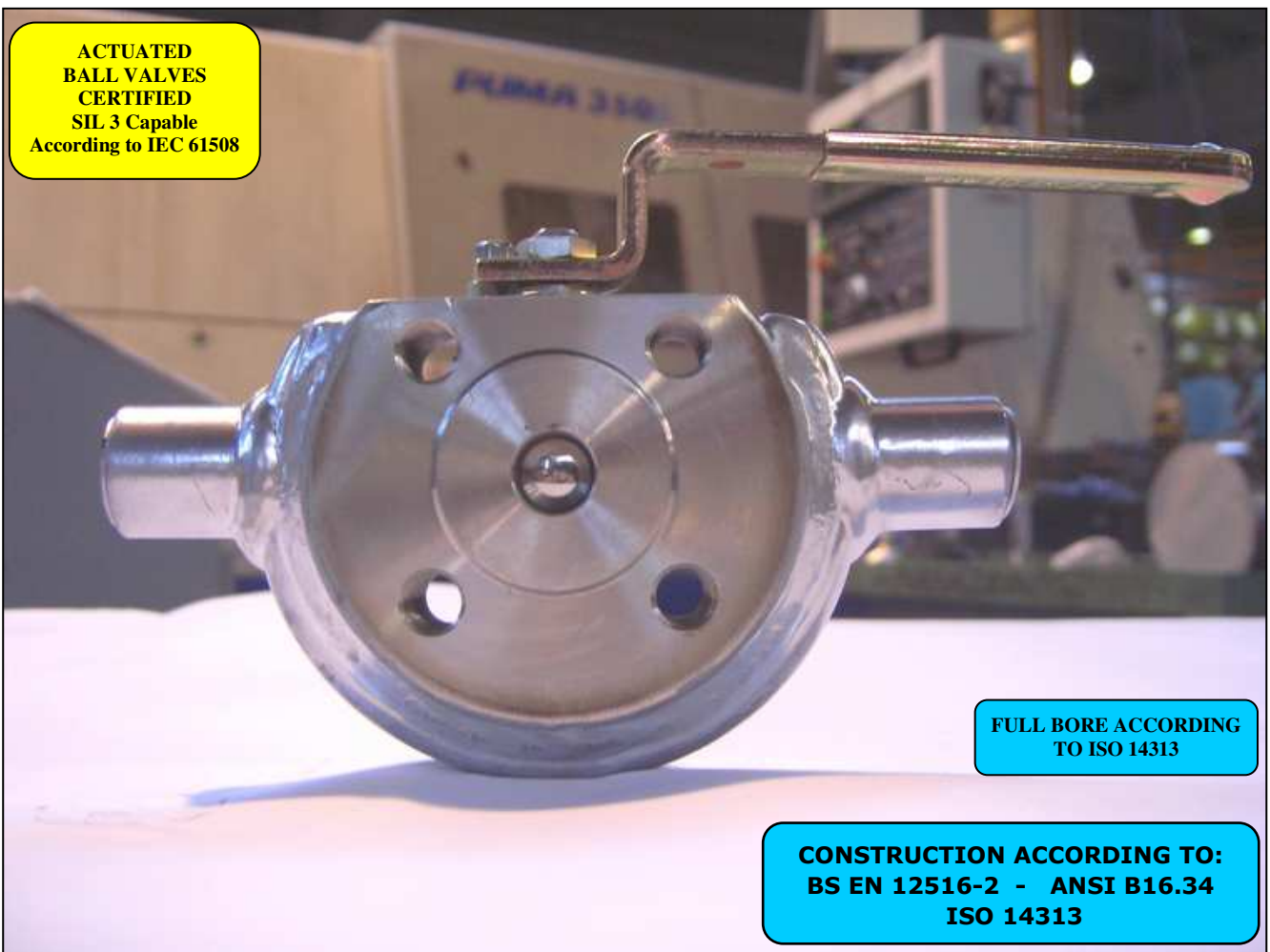

ACTUATED
BALL VALVES
CERTIFIED
SIL 3 Capable
According to IEC 61508

FULL BORE ACCORDING
TO ISO 14313

CONSTRUCTION ACCORDING TO:
BS EN 12516-2 - ANSI B16.34
ISO 14313

BALL VALVES "WAFER TYPE" FULL BORE WITH HEATING JACKET
ROBINETS A BOISSEAU SPHERIQUE
"WAFER" PASSAGE INTEGRAL AVEC ENVELOPPE
FLANSCHKUGELHÄHNE IN "KOMPAKTBAUWEISE"
VOLLER DURCHGANG MIT HEIZMANTEL

WEB SITE: WWW.ADLERSPA.COM

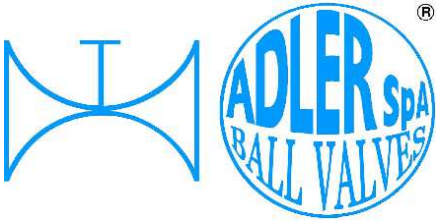

ISO 9001 by L.R.
 PED DIR. 2014/68/UE by L.R.
 ATEX DIR. 2014/34/UE by B.V.
 FIRE SAFE EXECUTION BS6755/API 607 by L.R.
 FIRE SAFE TESTED ISO 10497 by L.R.
 ISO 15848 by TÜV
 ANTISTATIC DEVICE by L.R.
 EAC CERTIFICATION by B.V.

TYPE
FX1
 PN 10 ÷ 40
 ANSI 150 ÷ 300

VALVOLA A SFERA "CORPO PIATTO" PASSAGGIO TOTALE CON CAMICIA DI RISCALDAMENTO
BALL VALVES "WAFER TYPE" FULL BORE WITH HEATING JACKET
ROBINETS A BOISSEAU SPHERIQUE "WAFER" PASSAGE INTEGRAL AVEC ENVELOPPE
FLANSCHKUGELHÄHNE IN "KOMPAKTBAUWEISE" VOLLER DURCHGANG MIT HEIZMANTEL

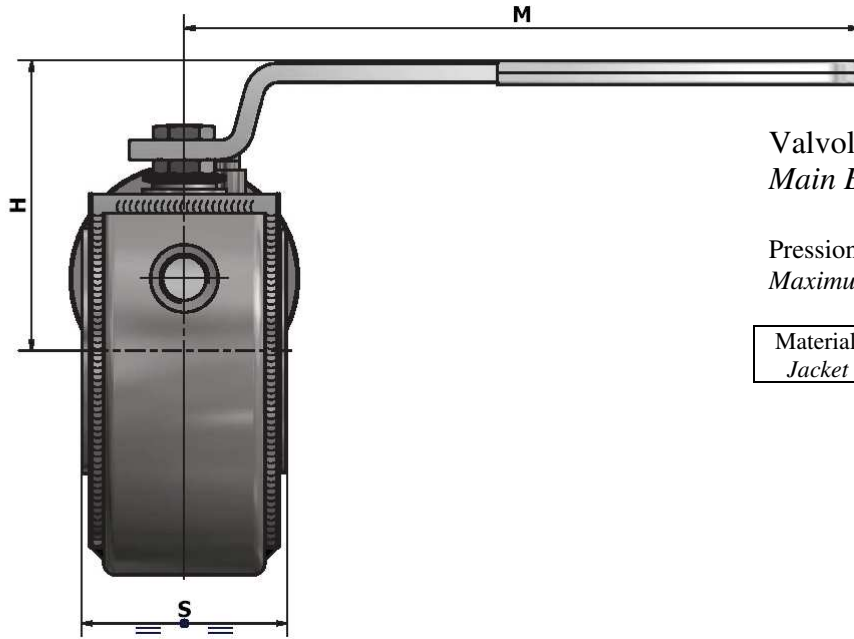

Valvola base FA1
 Main Ball Valve FA1

Pressione massima di lavoro nelle camicie 10 bar
 Maximum working pressure for jacket 10 bar

Materiale camicia	CARBON STEEL (STANDARD)
Jacket material	STAINLESS STEEL (OPTIONAL)

VISUALIZZA 3D
VIEW 3D

<https://adlerspa.com/prodotti/fx1>

Per montaggio con guarnizioni
 spiralmetalliche, contattare Adler Spa.
 For assembling with spiral-wound
 gaskets, contact Adler Spa

FLANGE DIMENSIONS
 according to
EN 1092-1 or ANSI B16.5
 see table
<https://adlerspa.com/wp-content/uploads/2023/11/Tabella-dimensioni-flange-valvole-Adler.pdf>

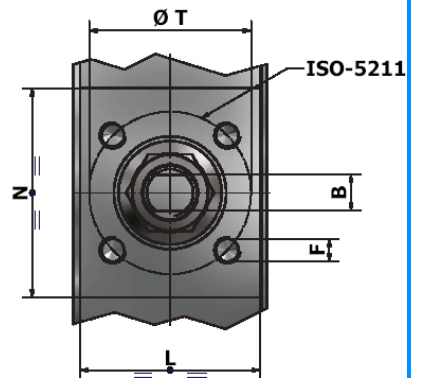
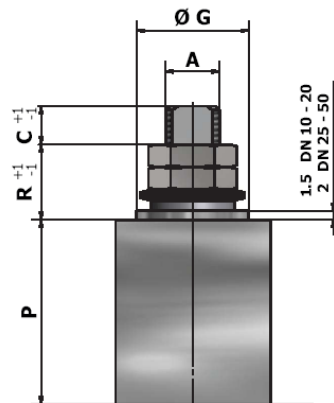
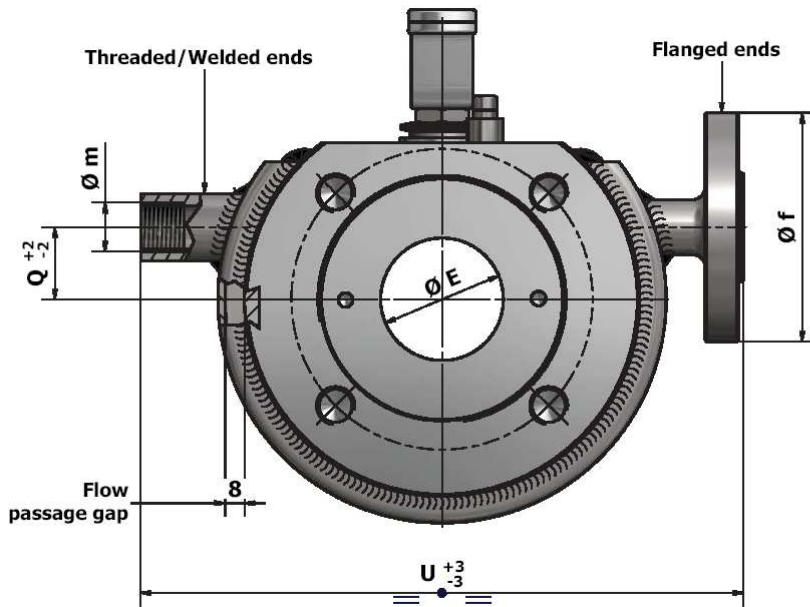



ISO 9001 by L.R.
 PED DIR. 2014/68/UE by L.R.
 ATEX DIR. 2014/34/UE by B.V.
 FIRE SAFE EXECUTION BS6755/API 607 by L.R.
 FIRE SAFE TESTED ISO 10497 by L.R.
 ISO 15848 by TÜV
 ANTISTATIC DEVICE by L.R.
 EAC CERTIFICATION by B.V.

TYPE
FX1
 PN 10 ÷ 40
 ANSI 150 ÷ 300

N.	DESCRIZIONE DESCRIPTION DESCRIPTION BESCHREIBUNG	MATERIALI MATERIALS MATERIAUX WERKSTOFFE
1	CORPO BODY CORPS MITTE	ASTM A105 ASTM A479 304/304L ASTM A479 316/316L
2	GHIERA INSERT EMBOUT GEWINDEDRUCKRING	ASTM A105 ASTM A479 304/304L ASTM A479 316/316L
3*	O-RING	FKM - (VITON)
4*	ANELLO SEAL ANNEAU DICHTUNGSRING	P.T.F.E.
5*	SEDE SEAT SIEGE SITZRING	P.T.F.E. + 15% FIBERGLASS
6	SFERA BALL BOULE KUGEL	ASTM A479 304/304L ASTM A351 CF8 ASTM A479 316/316L ASTM A351 CF8M
7	DISPOSITIVO ANTISTATICO ANTISTATIC DEVICE CONTACT ANTISTATIQUE ANTISTATIK VORRICHTUNG	ASTM A479 316/316L
8	STELO STEM TIGE SPINDEL	ASTM A479 304/304L ASTM A479 316/316L

N.	DESCRIZIONE DESCRIPTION DESCRIPTION BESCHREIBUNG	MATERIALI MATERIALS MATERIAUX WERKSTOFFE
9*	BUSSOLA STEM SEAL JOINT TIGE UNTERE SPINDELABDICHTUNG	P.T.F.E.
10*	PACCO A "V" CHEVRON RINGS JOINT A "V" 3 FACHE DACHMANSCHETTE	P.T.F.E. / GRAFITE P.T.F.E. / GRAPHITE P.T.F.E. / GRAPHITE P.T.F.E. / GRAPHIT
11	PREMIBUSSOLA PRESSING BUSH PRESSE RONDELLE STOPFBUCHSDRUCKRING	ASTM A479 304
12	MOLLE A TAZZA SPRING WASHERS RONDELLES BELLEVILLE TELLERFEDERN	C72/50Cr V ₄ ZINCATO - GALVANIZED - ZINGUE - VERZINKT X10CrNi18.8 ON REQUEST
13	VITE DI FERMO E FERMO PIN AND STOP PIN PLOT ET PLOT D'ARRET ANSCHLAGBOLZEN	UNI3740 8.8 ZINCATO - GALVANIZED - ZINGUE - VERZINKT UNI 3951 A2-70 ON REQUEST
14	DADO - CONTRODADO NUT - LOCK NUT ECROU - CONTRE-ECROU MUTTER - KONTERMUTTER	UNI 3740 - 6S ZINCATO - GALVANIZED ZINGUE - VERZINKT ASTM A479 304 ON REQUEST
15	LEVA WRENCH LEVIER HANDHEBEL	AISI 1010 GALVANIZED AND PAINTED FOR S.S. VALVES PAINTED FOR C.S. VALVES ASTM A479 304 ON REQUEST
16		

* RICAMBI CONSIGLIATI - RECOMMENDED SPARE PARTS - PIECES DE RECHANGE CONSEILLEES - ERSATZTEIL EMPFEHLUNG

ON REQUEST P.T.F.E. AVAILABLE CERTIFIED BAM, FDA, MOCA

DIMENSIONI - DIMENSION - DIMENSIONS - ABMESSUNGEN

DN	10	15	20	25	32	40	50	65	80	100	125	150	200	250	300
A	10	10	10	12	12	16	16	22	22						
B	6	6	6	8	8	10	10	14	14						
C	7	7	7	10	10	10	10	12	12						
E	15	15	19	25	30	38	51	64	76						
F	M5	M5	M5	M5	M5	M6	M6	M8	M8						
f	DN 15 PN 16														
ISO	F03	F03	F03	F03	F03	F05	F05	F07	F07						
G	25	25	25	25	25	35	35	55	55						
H	66	66	68	85	91	110	120	144	152						
L	33	33	33	40	48	58	79	97	113						
M	145	145	145	185	185	280	280	370	370						
m	Ø1/2" GAS														
N	69	69	78	81	105	102	102	85	80						
P	32,5	32,5	35	41	46,5	55	65	82	90,5						
R	7,5	7,5	7,5	16,5	16,5	19,5	19,5	24	24						
P	32,5	32,5	36,5	42,5	46,5	55									
R	8	8	6	17	16,5	20									
Q	/	/	/	/	25	30	30	45	50						
S	35	35	35	43	51	64	84	103	120						
T	36	36	36	36	36	50	50	70	70						
U	170	170	180	190	215	230	250	270	300						
Kg	2,6	2,6	2,9	3,8	5,3	8,7	13	20	26						

- DATI E CARATTERISTICHE SOGGETTI A VARIAZIONI SENZA PREAVVISO
- SPECIFICATIONS SUBJECT TO MODIFICATIONS WITHOUT PRIOR NOTICE
- TOUS DROITS DE MODIFICATION RESERVES
- KONSTRUKTIONÄNDERUNGEN VORBEHALTEN

PN 10 ÷ 40 - ANSI 150

ANSI 300



ADLER SpA - BALL VALVES
 20010 S. STEFANO TICINO (MI) ITALY V.le BORLETTI, 14 Tel. +39/02974842.11 FAX +39/0297271698
 E-mail: adler@adlerspa.com <http://www.adlerspa.com>

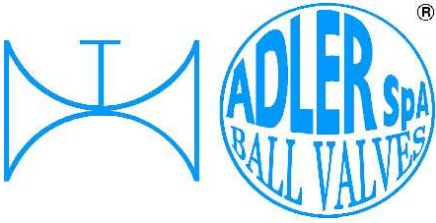

ISO 9001 by L.R.
 PED DIR. 2014/68/UE by L.R.
 ATEX DIR. 2014/34/UE by B.V.
 FIRE SAFE EXECUTION BS6755/API 607 by L.R.
 FIRE SAFE TESTED ISO 10497 by L.R.
 ISO 15848 by TÜV
 ANTISTATIC DEVICE by L.R.
 EAC CERTIFICATION by B.V.

TYPE
FX1
 PN 10 ÷ 40
 ANSI 150 ÷ 300

• ESECUZIONI • EXECUTIONS • EXECUTIONS • AUSFÜHRUNGEN



ONLY FOR VALVES \geq DN 50 **S**

FORO DI BILANCIAMENTO
 BALANCING HOLE
 TROU DE BALANCEMENT
 DRUCKENTLASTUNGSBOHRUNG

ON REQUEST AVAILABLE ON DN \leq 40



EXECUTION 4- 12

EXECUTION 6 - 16

S STANDARD

O OPTIONAL

1 **S**

-MONTAGGIO VITI – SCREW ASSEMBLING
 -MONTAGE VIS – EINBAU MIT SCHRAUBEN

2 **O**

-MONTAGGIO DI FONDO
 -END TANK ASSEMBLING
 -MONTAGE FOND DE CUVE
 -EINBAU ALS BODENABLASSKUGELHAHN

3 **O**

-MONTAGGIO BULLONI
 -BOLTS ASSEMBLING
 -MONTAGE BOULONS
 EINBAU MIT ZUGBOLZEN

4 **S**

-STELO ANTI ESPULSIONE – ANTI BLOW OUT STEM
 -TIGE ANTIEXPULSION – AUSBLASGESICHERETE WELLE

-PACCO A “V” – CHEVRON RINGS
 -JOINT A “V” – 3 FACHE DACHMANSCHETE
 ANTISTATIC DEVICE – ANTISTATIK VORRICHTUNG
 BS 5146

5 **O**

DN 10 ÷ 32

103 (DN 10 - 20)
 145 (DN 25 - 32)

69 (DN 10 - 20)
 79 (DN 25 - 32)

57

-MANIGLIA OVALE – OVAL HANDLE
 -LEVIER OVAL – HANDHEBEL IN OVALFORM

6 **O**

BREVETTO – PATENTED
00219688 - 21-04-1993

FKM (VITON)

-“O” RING STELO “O” RING ON STEM
 -TIGE AVEC “O” RING
 -“O” RING IM SPINDELBEREICH



ISO 9001 by L.R.
 PED DIR. 2014/68/UE by L.R.
 ATEX DIR. 2014/34/UE by B.V.
 FIRE SAFE EXECUTION BS6755/API 607 by L.R.
 FIRE SAFE TESTED ISO 10497 by L.R.
 ISO 15848 by TÜV
 ANTISTATIC DEVICE by L.R.
 EAC CERTIFICATION by B.V.

TYPE
FX1
 PN 10 ÷ 40
 ANSI 150 ÷ 300

7 **O**

-PROLUNGA STELO -STEM EXTENSION
 -TIGE PROLONGEE -SPINDELVERLÄNGERUNG

8 **O**

-PARTICOLARI INOX
 -STAINLESS STEEL DETAILS
 -ACCESSOIRES EN INOX
 -EDELSTAHLTEILE

9 **S**

-ATTACCO "ISO" -"ISO" CONNECTIONS
 -SYSTEM "ISO" -ANSCHLUSS "ISO"

10 **S**

-SFERA CONTENUTA -CONTENTS BALL
 -BOULE CONTENUE
 -NICHT RAUSRAGENDE KUGEL

11 **O**

-TENUTE INTEGRALE -POCKETLESS SEATS
 -TENUE INTEGRALE -TOTRAUMARM
 -P.T.F.E. / R.T.F.E.

12 **O**

FIRE SAFE
 ISO 10497 "ISO-FT"
 (BS 6755 / API 607)

13 **S**

-DOPPIA TENUTA -DOUBLE SEALS
 -DOUBLE ETANCHEITE -DOPPELTE ABDICHTUNG
 -GHIERA A BATTUTA -METAL BEATING RING
 -EMBOUT AVEC BATTUE MECANIQUE
 -METALLISCHER ANSCHLAG DES
 GEWINDEDRUCKRINGS

14 **S**

VEDERE / SEE ANSI B16.34

FLUSSO
 FLOW

-FORO DI SCARICO NELLA SFERA
 -OVERPRESSURE HOLE INTO BALL
 -TROU DECOMPRESSION DANS LA BOULE
 -ENTLASTUNGSBOHRUNG IN DER KUGEL
 VALVOLA MONO DIREZIONALE
 MONO-DIRECTIONAL VALVE

DIMENSIONS CHECK

16 **O**

-FIRE SAFE ISO FT+ "O" RING STELO
 -FIRE SAFE ISO FT+ "O" RING ON STEM
 -SECURITE FEU ISO FT+ TIGE AVEC "O" RING
 -FEUERSICHERE AUSFÜHRUNG ISO FT +
 "O" RING IM SPINDELBEREICH

FIRE SAFE ISO FT CERTIFICATION

18 **O**

-SFERA CIECA PER CAMPIONATURA
 -BLIND BALL FOR SAMPLING
 -PRISE-ECHANTILLON
 KUGEL FÜR PROBEHAHME



ISO 9001 by L.R.
 PED DIR. 2014/68/UE by L.R.
 ATEX DIR. 2014/34/UE by B.V.
 FIRE SAFE EXECUTION BS6755/API 607 by L.R.
 FIRE SAFE TESTED ISO 10497 by L.R.
 ISO 15848 by TÜV
 ANTISTATIC DEVICE by L.R.
 EAC CERTIFICATION by B.V.

TYPE
FX1
 PN 10 ÷ 40
 ANSI 150 ÷ 300

VITI D'ASSEMBLAGGIO PER FX1 - ASSEMBLING SCREWS FOR FX1 - VIS D'ASSEMBLAGE POUR FX1- MONTAGESCHRAUBEN FÜR FX1

N° VITI - DIMENSIONE • N° SCREW - DIMENSIONS • N° VIS - DIMENSIONS • N° SCHRAUBEN-ABMESSUNGEN

EUROPEAN NORM

DN PN	10-15		20		25		32		40		50		65		80		100		125		150		200	
16	8	M12 X30	8	M12 X30	8	M12 X30	8	M16 X35	8	M16 X35	8	M16 X40												
25	8	M12 X30	8	M12 X35	8	M12 X35	8	M16 X40	8	M16 X40	8	M16 X40												
40	8	M12 X30	8	M12 X35	8	M12 X35	8	M16 X40	8	M16 X40	8	M16 X40												

ANSI METRIC

(STANDARD ADLER)

Ø Rating	1/2"		3/4"		1"		1 1/4"		1 1/2"		2"		2 1/2"		3"		4"		5"		6"		8"	
150	8	M14 X30	8	M14 X30	8	M14 X30	8	M14 X35	8	M14 X35	8	M16 X40												

ANSI B1.1 UNC

(ON REQUEST)

Ø Rating	1/2"		3/4"		1"		1 1/4"		1 1/2"		2"		2 1/2"		3"		4"		5"		6"		8"	
150	8	1/2 X 1 1/4	8	1/2 X 1 1/4	8	1/2 X 1 1/4	8	1/2 X 1 1/4	8	1/2 X 1 1/2	8	5/8 X 1 1/2												

Length of screws calculated considering a gasket with thickness of 2mm.

