



ISO 9001 by L.R.  
PED DIR. 2014/68/UE by L.R.  
ATEX DIR. 2014/34/UE by B.V.  
FIRE SAFE EXECUTION BS6755/API 607 by L.R.  
FIRE SAFE TESTED ISO 10497 by L.R.  
ISO 15848 by TÜV  
ANTISTATIC DEVICE by L.R.  
EAC CERTIFICATION by B.V.

TYPE  
**VG2**  
ANSI 300

NORME E DIRETTIVE APPLICATE DISPONIBILI AL SEGUENTE LINK:  
STANDARD AND DIRECTIVE APPLIED AVAILABLE AT FOLLOWING LINK:  
[http://www.adlerspa.com/pdf/NORME\\_ADLER.pdf](http://www.adlerspa.com/pdf/NORME_ADLER.pdf)

## VALVOLE A SFERA "ANSI B16.10" PASSAGGIO VENTURI

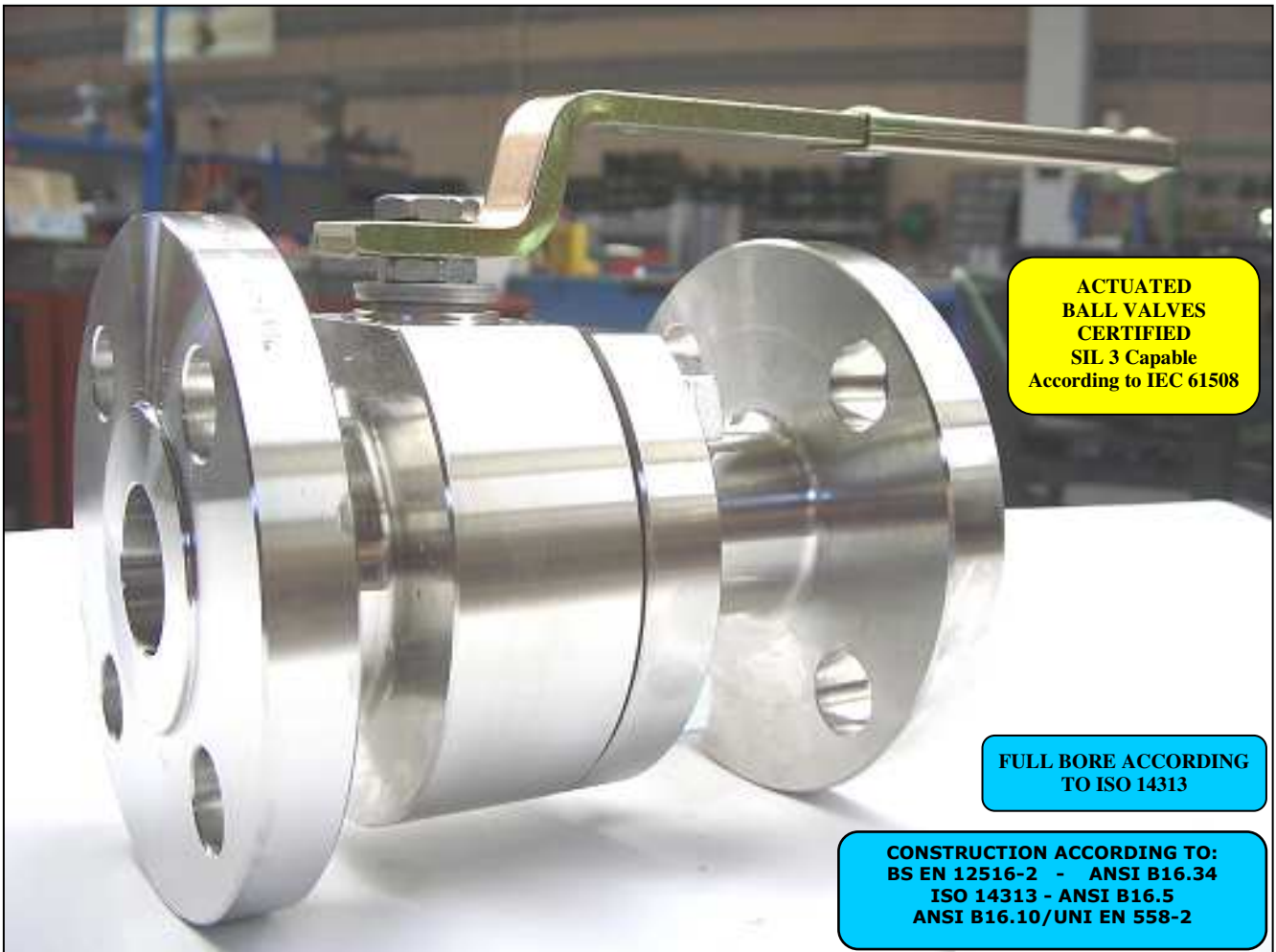

ACTUATED  
BALL VALVES  
CERTIFIED  
SIL 3 Capable  
According to IEC 61508

FULL BORE ACCORDING  
TO ISO 14313

CONSTRUCTION ACCORDING TO:  
BS EN 12516-2 - ANSI B16.34  
ISO 14313 - ANSI B16.5  
ANSI B16.10/UNI EN 558-2

**BALL VALVES**  
**"ANSI B 16.10" VENTURI PORT**  
**ROBINETS A BOISSEAU SPHERIQUE**  
**"ANSI B 16.10" PASSAGE VENTURI**  
**FLANSCHKUGELHÄHNE IN "ANSI B 16.10"**  
**REDUZIERTER DURCHGANG**

WEB SITE: [WWW.ADLERSPA.COM](http://WWW.ADLERSPA.COM)



ISO 9001 by L.R.  
 PED DIR. 2014/68/UE by L.R.  
 ATEX DIR. 2014/34/UE by B.V.  
 FIRE SAFE EXECUTION BS6755/API 607 by L.R.  
 FIRE SAFE TESTED ISO 10497 by L.R.  
 ISO 15848 by TÜV  
 ANTISTATIC DEVICE by L.R.  
 EAC CERTIFICATION by B.V.

TYPE  
**VG2**  
 ANSI 300

VALVOLA A SFERA "ANSI B 16.10" SPLIT BODY PASSAGGIO TOTALE  
 BALL VALVES "ANSI B 16.10" SPLIT BODY FULL BORE  
 ROBINETS A BOISSEAU SPHERIQUE "ANSI B 16.10" PASSAGE INTEGRAL 2 PIECES  
 FLANSCHKUGELHÄHNE IN "ANSI B 16.10" VOLLER DURCHGANG ZWEIFTEILIGES GEHÄUSE

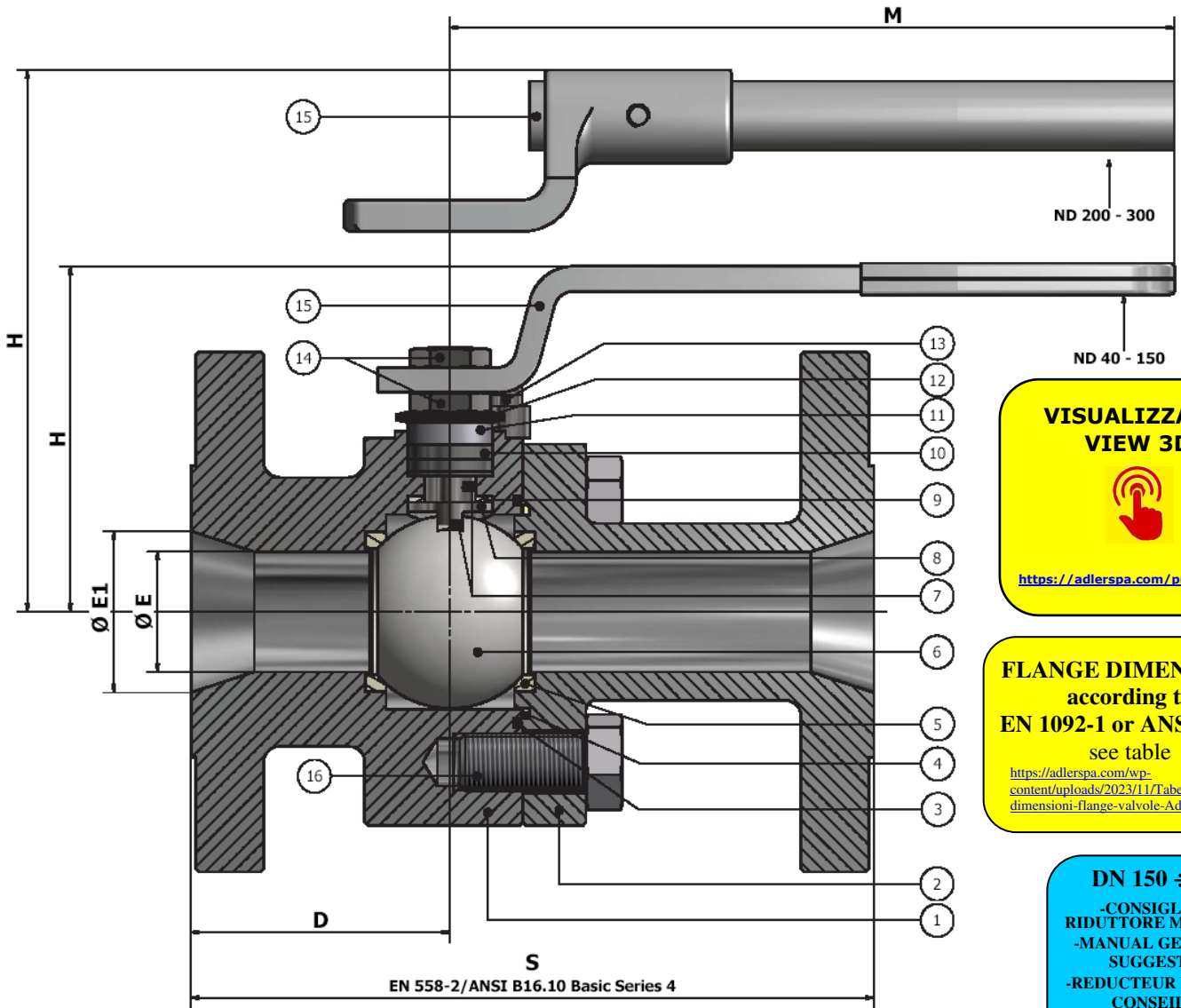

**VISUALIZZA 3D VIEW 3D**

<https://adlerspa.com/prodotti/vg2>

**FLANGE DIMENSIONS according to EN 1092-1 or ANSI B16.5 see table**

<https://adlerspa.com/wp-content/uploads/2023/11/Tabella-dimensioni-flange-valvole-Adler.pdf>

**DN 150 ÷ 250**

- CONSIGLIATO RIDUTTORE MANUALE
- MANUAL GEAR BOX SUGGESTED
- REDUCTEUR MANUEL CONSEILLE
- EMPFEHLEN WIR EIN HANDGETRIEBE

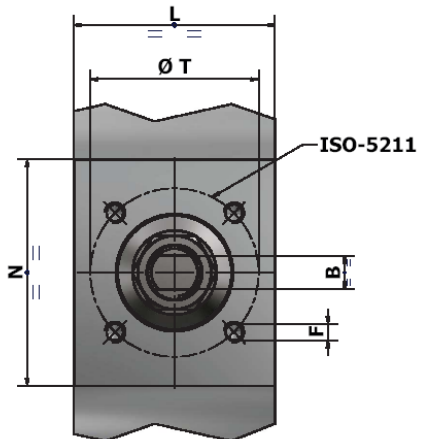
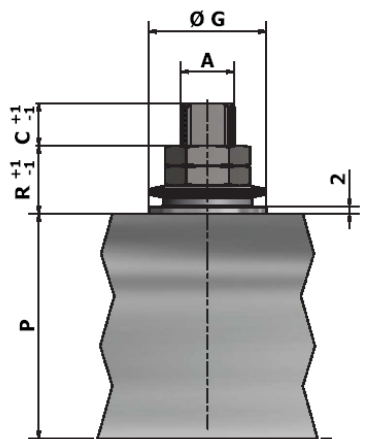



ISO 9001 by L.R.  
 PED DIR. 2014/68/UE by L.R.  
 ATEX DIR. 2014/34/UE by B.V.  
 FIRE SAFE EXECUTION BS6755/API 607 by L.R.  
 FIRE SAFE TESTED ISO 10497 by L.R.  
 ISO 15848 by TÜV  
 ANTISTATIC DEVICE by L.R.  
 EAC CERTIFICATION by B.V.

TYPE  
**VG2**  
 ANSI 300

N.	DESCRIZIONE DESCRIPTION BESCHREIBUNG	MATERIALI MATERIALS MATERIAUX WERKSTOFFE
1	CORPO BODY CORPS MITTE	ASTM A105 ASTM A479 304/304L ASTM A479 316/316L ASTM A 351 CF8M
2	LATERALE END LATERAL ENDE	ASTM A105 ASTM A479 304/304L ASTM A479 316/316L ASTM A 351 CF8M
3*	O-RING	FKM - (VITON)
4*	ANELLO SEAL ANNEAU DICHTUNGSRING	P.T.F.E.
5*	SEDE SEAT SIEGE SITZRING	R.P.T.F.E.
6	SFERA BALL BOULE KUGEL	ASTM A479 304/304L ASTM A351 CF8 ASTM A479 316/316L ASTM A351 CF8M
7	DISPOSITIVO ANTISTATICO ANTISTATIC DEVICE CONTACT ANTISTATIQUE ANTISTATIK VORRICHTUNG	ASTM A479 316/316L
8	STELO STEM TIGE SPINDEL	ASTM A479 304/304L ASTM A479 316/316L

N.	DESCRIZIONE DESCRIPTION BESCHREIBUNG	MATERIALI MATERIALS MATERIAUX WERKSTOFFE
9*	BUSSOLA STEM SEAL JOINT TIGE UNTERE SPINDELABDICHTUNG	P.T.F.E.
10*	PACCO A "V" CHEVRON RINGS JOINT A "V" 3 FACHE DACHMANSCHETTE	P.T.F.E. / GRAFITE P.T.F.E. / GRAPHITE P.T.F.E. / GRAPHITE P.T.F.E. / GRAPHIT
11	PREMIBUSSOLA PRESSING BUSH PRESSE RONDELLE STOPFBUCHSDRUCKRING	ASTM A479 304
12	MOLLE A TAZZA SPRING WASHERS RONDELLES BELLEVILLE TELLERFEDERN	C72/50Cr V4 ZINCATO - GALVANIZED - ZINGUE - VERZINKT X10CrNi18.8 ON REQUEST
13	VITE DI FERMO E FERMO PIN AND STOP PIN PLOTT ET PLOT D'ARRET ANSCHLAGBOLZEN	UNI3740 8.8 ZINCATO - GALVANIZED - ZINGUE - VERZINKT UNI 3951 A2-70 ON REQUEST
14	DADO - CONTRODADO NUT - LOCK NUT ECROU - CONTRE-ECROU MUTTER - KONTERMUTTER	UNI 3740 - 6S ZINCATO - GALVANIZED ZINGUE - VERZINKT ASTM A479 304 ON REQUEST
15	LEVA WRENCH LEVIER HANDHEBEL	AISI 1010 GALVANIZED AND PAINTED FOR S.S. VALVES PAINTED FOR C.S. VALVES ASTM A479 304 ON REQUEST
16	VITE SCREW VIS SCHRAUBE	UNI 3740 8.8 ZINCATO - GALVANIZED - ZINGUE - VERZINKT UNI 3951 A2-70 ON REQUEST

\* RICAMBI CONSIGLIATI - RECOMMENDED SPARE PARTS - PIECES DE RECHANGE CONSEILLEES - ERSATZTEIL EMPFEHLUNG

ON REQUEST P.T.F.E. AVAILABLE CERTIFIED BAM, FDA, MOCA

### DIMENSIONI - DIMENSION - DIMENSIONS - ABMESSUNGEN

DN	15	20	25	32	40	50	65	80	80	100	125	150	150	200	250	300
A					12	16		16	22	22		30	30	42	48	
B					8	10		10	14	14		18	18	28	32	
C					7	8		8	12	16		17	17	19	19	
D					78	82		117	107,5	109		167	157	149	173	
E					30	38		51	64	76		101	118	152	187	
F					M5	M6		M6	M8	M8		M8	M10	M12	M16	
ISO					F03	F05		F05	F07	F07		F07	F10	F12	F14	
G					25	35		35	55	55		55	70	85	100	
H					119	110		120	143	152		174	188	256	286	
L					34	50		55	72	72		73	115	135	165	
M					185	280		280	370	370		470	650	750	900	
N					40	78		64	83	80		115	100	140	147	
P					46,5	55		65	82	90,5		99,5	120	144	172,5	
R					17	20		20	23	23		26	19	34	36	
S					191	216		283	283	305		403	403	419	457	
T					36	50		50	70	70		70	102	125	140	
~Kg					9	14,5		26	26	39		84	79	120	250	

VEDERE TYPE  
 SEE FG2  
 VOIR ANSI  
 SIEHE 300

- DATI E CARATTERISTICHE SOGGETTI A VARIAZIONI SENZA PREAVVISO
- SPECIFICATIONS SUBJECT TO MODIFICATIONS WITHOUT PRIOR NOTICE
- TOUS DROITS DE MODIFICATION RESERVES
- KONSTRUKTIONÄNDERUNGEN VORBEHALTEN



ADLER SpA - BALL VALVES  
 20010 S. STEFANO TICINO (MI) ITALY V.le BORLETTI, 14 Tel. +39/02974842.11 FAX +39/0297271698  
 E-mail: [adler@adlerspa.com](mailto:adler@adlerspa.com) <http://www.adlerspa.com>



ISO 9001 by L.R.  
 PED DIR. 2014/68/UE by L.R.  
 ATEX DIR. 2014/34/UE by B.V.  
 FIRE SAFE EXECUTION BS6755/API 607 by L.R.  
 FIRE SAFE TESTED ISO 10497 by L.R.  
 ISO 15848 by TÜV  
 ANTISTATIC DEVICE by L.R.  
 EAC CERTIFICATION by B.V.

TYPE  
**VG2**  
 ANSI 300

• ESECUZIONI • EXECUTIONS • EXECUTIONS • AUSFÜHRUNGEN



EXECUTION 4- 12

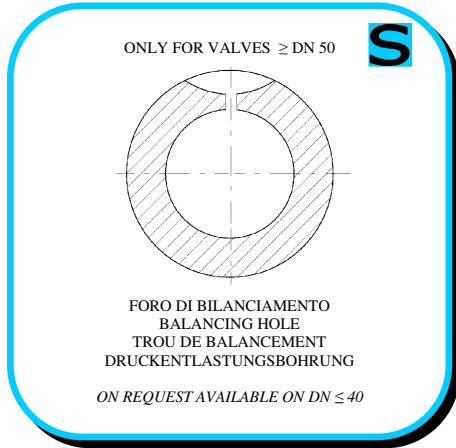

EXECUTION 6 - 16

**S** STANDARD

**O** OPTIONAL

**1** **S**

**CARBON STEEL**  
 ASTM A105  
 DN 15 ÷ 200

**HARDNESS TOOL**

**3** **O**

**STAINLESS STEEL**  
 ASTM A479 304  
 DN 15 ÷ 100

ASTM A351 CF8  
 DN 150 ÷ 300

**4** **S**

-STELO ANTI ESPULSIONE -ANTI BLOW OUT STEM  
 -TIGE ANTIEXPULSION -AUSBLASGESICHERTE WELLE

-PACCO A "V" -CHEVRON RINGS  
 -JOINT A "V" -3 FACHE DACHMANSCHETE  
 ANTISTATIC DEVICE ANTISTATIK VORRICHTUNG  
 BS 5146

**DIMENSIONS CHECK**

**6** **O**

**BREVETTO - PATENTED**  
 00219688 - 21-04-1993  
 FKM (VITON)

-“O” RING STELO “O” RING ON STEM  
 -TIGE AVEC “O” RING  
 -“O” RING IM SPINDELBEREICH

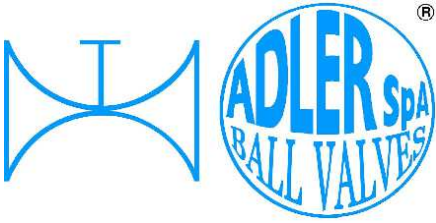

ISO 9001 by L.R.  
 PED DIR. 2014/68/UE by L.R.  
 ATEX DIR. 2014/34/UE by B.V.  
 FIRE SAFE EXECUTION BS6755/API 607 by L.R.  
 FIRE SAFE TESTED ISO 10497 by L.R.  
 ISO 15848 by TÜV  
 ANTISTATIC DEVICE by L.R.  
 EAC CERTIFICATION by B.V.

TYPE  
**VG2**  
 ANSI 300

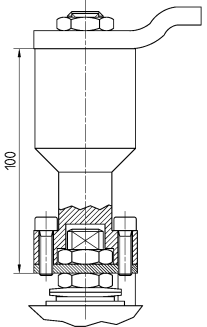
**7** 

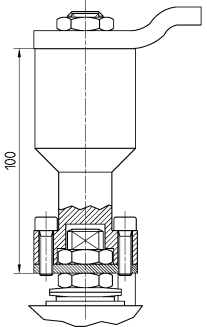

-PROLUNGA STELO -STEM EXTENSION  
 -TIGE PROLONGEE -SPINDELVERLÄNGERUNG

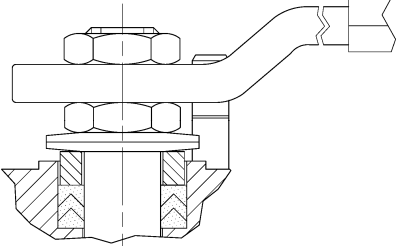
**8** 

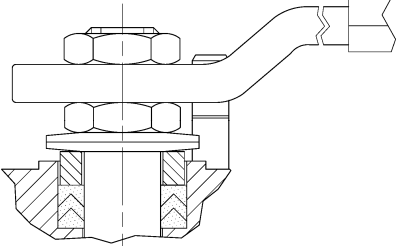

-PARTICOLARI INOX  
 -STAINLESS STEEL DETAILS  
 -ACCESSOIRES EN INOX  
 -EDELSTAHLTEILE

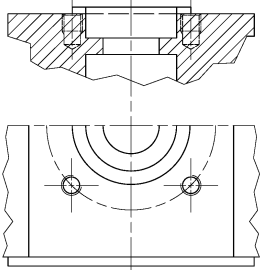
**9** 

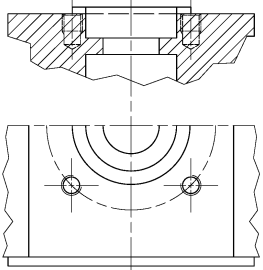

-ATTACCO "ISO" -"ISO" CONNECTIONS  
 -SYSTEM "ISO" -ANSCHLUSS "ISO"

**10** 

**PN  
 25 ÷ 40**

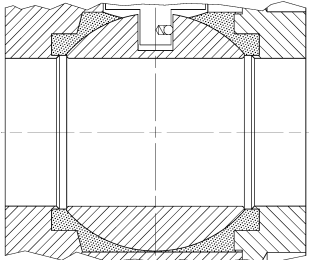
**11** 

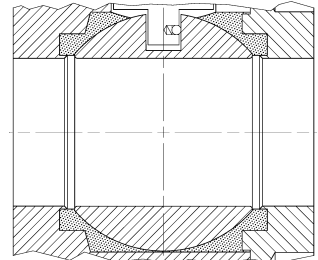

-TENUTE INTEGRALE -POCKETLESS SEATS  
 -TENUE INTEGRALE -TOTRAUMARM  
 -P.T.F.E. / R.T.F.E.

**12** 

**FIRE SAFE  
 ISO 10497 "ISO-FT"  
 (BS 6755 / API 607)**

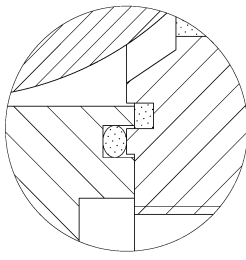

**13** 

**BREVETTO - PATENTED  
 00219619**

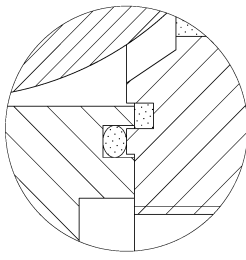

-DOPPIA TENUTA -DOUBLE SEALS  
 -DOUBLE ETANCHEITE -DOPPELTE ABDICHTUNG  
 -LATERALE A BATTUTA -METAL BEATING END  
 -LATERAL AVEC BATTUE MECANIQUE  
 -METALLISCHER ANSCHLAG DES  
 GEGENGEHÄUSES

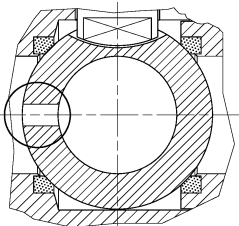
**14** 

**VEDERE / SEE ANSI B16.34**

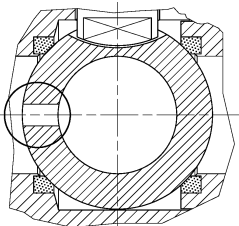

FLUSSO  
 FLOW

-FORO DI SCARICO NELLA SFERA  
 -OVERPRESSURE HOLE INTO BALL  
 -TROU DECOMPRESSION DANS LA BOULE  
 -ENTLASTUNGSBOHRUNG IN DER KUGEL  
**VALVOLA MONO DIREZIONALE  
 MONO-DIRECTIONAL VALVE**

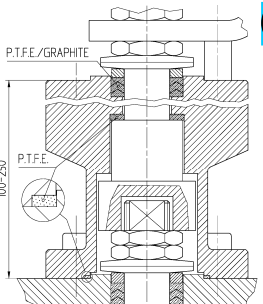
**15** 

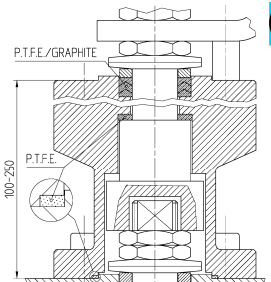

P.T.F.E./GRAPHITE  
 100-250  
 P.T.F.E.

-SERVIZIO CRIOGENICO - CRYOGENIC SERVICE  
 -SERVICE CRYOGÉNIQUE  
 -TIEFTEMPERATUR SERVICE

**16** 

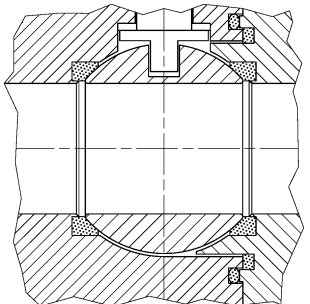

-FIRE SAFE ISO FT+ "O" RING STELO  
 -FIRE SAFE ISO FT+ "O" RING ON STEM  
 -SECURITE FEU ISO FT+ TIGE AVEC "O" RING  
 -FEUERSICHERE AUSFÜHRUNG ISO FT+  
 "O" RING IM SPINDELBEREICH

**17** 

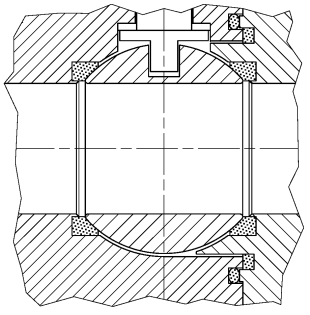

-TENUTA INTEGRALE METALLICA  
 -METALLIC POCKET LESS SEATS  
 -TENUE INTEGRALE METALLIQUE  
 -TOTRAUMARM METALLISCH

**GEAR BOX  
 AG SERIES**



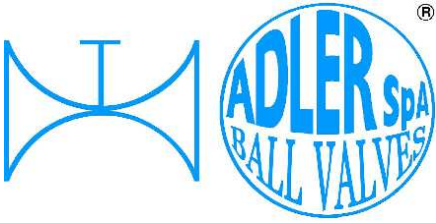

ISO 9001 by L.R.  
 PED DIR. 2014/68/UE by L.R.  
 ATEX DIR. 2014/34/UE by B.V.  
 FIRE SAFE EXECUTION BS6755/API 607 by L.R.  
 FIRE SAFE TESTED ISO 10497 by L.R.  
 ISO 15848 by TÜV  
 ANTISTATIC DEVICE by L.R.  
 EAC CERTIFICATION by B.V.

TYPE  
**VG2**  
 ANSI 300

**DIMENSIONI FLANGE - FLANGE DIMENSION - DIMENSIONS BRIDES - FLANSCHANSCHLUSSMASSE**

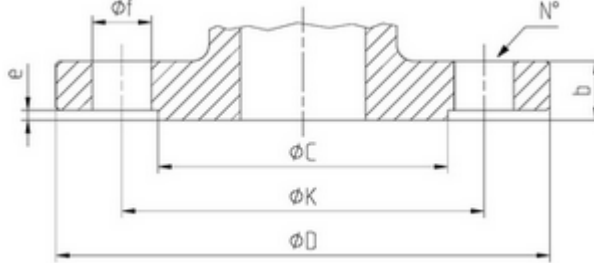

**ANSI B16.5**

DN	Ref.	1/2"	3/4"	1"	1 1/4"	1 1/2"	2"	2 1/2"	3"	4"	5"	6"	8"	10"	12"	
ANSI 300 RF	D	95.3	117.4	124	133.4	155.5	165.1	190.5	209.6	254	279.4	317.5	381	444.5	520.7	
	C	35.1	43	50.8	63.5	73.2	92	104.7	127	157.3	185.7	215.9	269.8	323.9	381	
	K	66.5	82.6	88.9	98.6	114.3	127	149.4	168.1	200.2	134.9	269.7	330.2	387.4	450.9	
	N°	4	4	4	4	4	8	8	8	8	8	12	12	16	16	
	f	15.8	19.1	19.1	19.1	22.4	19.1	22.4	22.4	22.4	22.4	22.4	22.4	25.4	28.5	31.8
	b	14.3	15.8	17.6	19.1	20.6	22.4	25.4	28.5	31.8	35.1	36.6	41.2	47.8	50.8	
	e	1.6	1.6	1.6	1.6	1.6	1.6	1.6	1.6	1.6	1.6	1.6	1.6	1.6	1.6	

**EN 1092-1 (OPTIONAL)**

DN	Ref.	10	15	20	25	32	40	50	65	80	100	125	150	200	250	300
PN 25	D	90	95	105	115	140	150	165	185	200	235	270	300	360	425	
	C	40	45	58	68	78	88	102	122	138	162	188	218	278	335	
	K	60	65	75	85	100	110	125	145	160	190	220	250	310	370	
	N°	4	4	4	4	4	4	4	8	8	8	8	8	12	12	
	f	14	14	14	14	18	18	18	18	18	22	26	26	26	30	
	b	16	16	18	18	18	18	20	22	24	24	26	28	30	32	
	e	2	2	2	2	2	3	3	3	3	3	3	3	3	3	
PN 40	D	90	95	105	115	140	150	165	185	200	235	270	300	375	450	
	C	40	45	58	68	78	88	102	122	138	162	188	218	285	345	
	K	60	65	75	85	100	110	125	145	160	190	220	250	320	385	
	N°	4	4	4	4	4	4	4	8	8	8	8	8	12	12	
	f	14	14	14	14	18	18	18	18	18	22	26	26	30	33	
	b	16	16	18	18	18	18	20	22	24	24	26	28	34	38	
	e	2	2	2	2	2	3	3	3	3	3	3	3	3	3	

\* n°8 fori

